

1 The Mass Flow and Proposed Management of
2 Bisphenol A in Selected Norwegian Waste Streams

3
4 *Hans Peter H. Arp,^{1*} Nicolas A. O. Morin,^{1,2} Sarah E. Hale,¹ Gudny Okkenhaug,^{1,3}*

5 *Knut Breivik,^{4,5} and Magnus Sparrevik^{1,6}*

6
7 ¹Norwegian Geotechnical Institute (NGI), P.O. Box 3930, Ullevål Stadion, N-0806 Oslo, Norway

8
9 ²Environmental and Food Laboratory of Vendée (LEAV), Department of Chemistry, Rond-point
10 Georges Duval CS 80802, 85021 La Roche-sur-Yon, France

11
12 ³Department of Environmental Sciences, Norwegian University of Life Sciences (NMBU), P.O.
13 Box 5003, NO-1432 Ås, Norway

14
15 ⁴ Norwegian Institute for Air Research, P.O. Box 100, NO-2027 Kjeller, Norway

16
17 ⁵ Department of Chemistry, University of Oslo, P.O. Box 1033, NO-0315 Oslo, Norway

18
19 ⁶ Department of Industrial Economics and Technology Management. Norwegian University of
20 Technology, Trondheim, Norway

21
22
23 *Corresponding Author: E-mail: hpa@ngi.no. Tel. +47 950 20 667

24

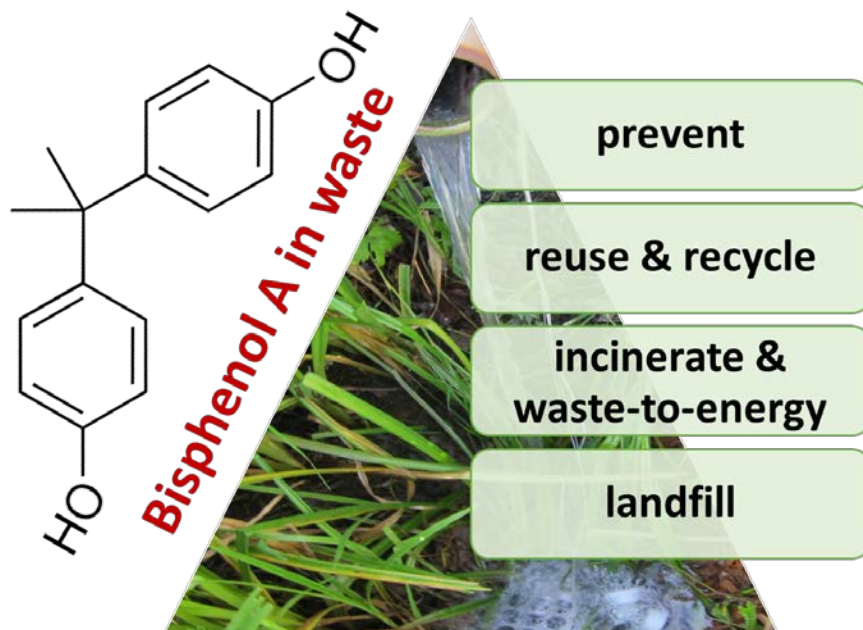

26

27

28

29

30

31

32

33

34 **Abstract**

35 Current initiatives for waste-handling in a circular economy favor prevention and recycling over
36 incineration or landfilling. However, the impact of such a transition on environmental emissions
37 of contaminants like bisphenol A (BPA) during waste-handling is not fully understood. To address
38 this, a material flow analysis (MFA) was constructed for selected waste categories in Norway, for
39 which the amount recycled is expected to increase in the future; glass, vehicle, electronic, plastic
40 and combustible waste. Combined, 92 tons/y of BPA are disposed of via these waste categories in
41 Norway, with 98.5% associated with plastic and electronic waste. During the model year 2011, the
42 MFA showed that BPA in these waste categories was destroyed through incineration (60%),
43 exported for recycling into new products (35%), stored in landfills (4%) or released into the
44 environment (1%). Landfilling led to the greatest environmental emissions (up to 13% of landfilled
45 BPA), and incinerating the smallest (0.001% of incinerated BPA). From modelling different waste
46 management scenarios, the most effective way to reduce BPA emissions are to incinerate BPA-
47 containing waste and avoid landfilling it. A comparison of environmental and human BPA
48 concentrations with CoZMoMAN exposure model estimations suggested that waste emissions are
49 an insignificant regional source. Nevertheless, from monitoring studies, landfill emissions can be
50 a substantial local source of BPA. Regarding the transition to a circular economy, it is clear that
51 disposing of less BPA-containing waste and less landfilling would lead to lower environmental
52 emissions, but several uncertainties remain regarding emissions of BPA during recycling,
53 particularly for paper and plastics. Future research should focus on the fate of BPA, as well as
54 BPA alternatives, in emerging reuse and recycling processes, as part of the transition to a circular
55 economy.

56 Keywords: Bisphenol A, waste hierarchy, mass flow, WEEE, plastic

57 **1 Introduction**

58 Bisphenol A (BPA) is a hazardous, endocrine disrupting compound (Vandenberg et al.,
59 2007) that is used in many plastics, epoxy resins, paper and paper products (EC, 2008; Liao and
60 Kannan, 2011). BPA is subject to an increasing number of restrictions in certain products that
61 present a human exposure risk, such as infant feeding bottles (e.g. EU directive 2011/8/EU).
62 Despite these restrictions, the worldwide production of BPA is expected to grow by 5.1% from
63 2014 to 2019 (TechNavio, 2015), with 2012 production levels estimated at 4.6 million tons . An
64 emerging issue in Europe is what effect policy initiatives that set targets to change waste
65 management practices as part of the transition to a circular economy (EC, 2015b) will have on
66 hazardous compounds like BPA. The two main implications under discussion are, firstly, how this
67 will influence environmental emissions, and secondly, how this will effect exposure through
68 occurrence in recycled products. (Pivnenko et al., 2016a). In this study, we provide an examination
69 of the first issue, how waste-handling alternatives will influence the environmental emissions of
70 BPA.

71 BPA is water soluble (water solubility 300 mg/L, log Kow = 3.4) (Cousins et al., 2002),
72 and therefore BPA-containing waste can readily release BPA into the aqueous environment
73 (Cousins et al., 2002; Morin et al., 2015). In Norway and elsewhere, municipal and industrial waste
74 landfill leachate often has BPA concentrations that are substantially higher than its chronic
75 predicted no-effect concentration of 1.6 µg/L (e.g. a Norwegian survey reported an interquartile
76 range of 1 – 62 µg/L, maximum 692 µg/L) (Arp, 2013; Morin et al., 2015). Therefore, waters
77 receiving landfill leachate are particularly vulnerable. Wastewater treatment plants (WTP), be they
78 municipal or for a particular waste handling facility, are poorly equipped to eliminate BPA from
79 leachate, as is evident by the frequent detection of BPA in WTP effluent (Guerra et al., 2015; Lee

80 et al., 2015; Mohapatra et al., 2010; Yu et al., 2015). BPA is not prone to long-range environmental
81 transport, having a half-life in water of 0.5 to 6 days (Klečka et al., 2001). However, in waters
82 impacted by waste-handling facilities, a sustained elevated presence can be expected. A sound
83 understanding of BPA emissions from waste is therefore important in order to establish effective
84 waste-management strategies that reduce BPA-related risks to the environment.

85 Previous studies to investigate emissions of BPA into the environment have focused on
86 BPA-rich products such as polycarbonate plastic and bottles (Cooper et al., 2011; Sajiki and
87 Yonekubo, 2003, 2004), waste electrical and electronic equipment (WEEE) (Zhang et al., 2016)
88 and paper (Geens et al., 2012; Liao and Kannan, 2011; Pivnenko et al., 2016b; Pivnenko et al.,
89 2015b), or specific waste products such as WTP sludge (Mohapatra et al., 2010). Modelling and
90 monitoring studies have also been developed for an area near a paper-processing plant (Fürhacker
91 et al., 2000), as well as the EU and US on the regional scale (Cousins et al., 2002).

92 In this current study, we aim to better understand how changes in waste-management can
93 influence environmental emissions of BPA from waste-handling practices, and in particular those
94 within Norway. The context for this work is that European policy makers have recently set
95 ambitious targets to landfill less waste and recycle more as part of the shift to a circular economy
96 (EC, 2015a, b, c). In order to address this, the present study presents: (i) a Material Flow Analysis
97 (MFA) of BPA in selected types of wastes in Norway as they undergo sorting and defragmenting,
98 landfilling, incineration and recycling, accounting for environmental emissions to air, water and
99 water treatment plant (WTP) sludge; (ii) an assessment of whether waste-handling emissions
100 contribute substantially to environmental and human exposures on a regional scale; and (iii) a
101 method that allows the manipulation of the MFA to estimate differences in BPA emissions caused

102 by different waste-management scenarios that may be adopted in the near future as part of the
103 transition towards a circular economy.

104

105 **2 Materials and methods**

106 **2.1 System description**

107 Table 1 presents a conceptual sketch of the waste-management system boundaries used to
108 construct the MFA for the Norwegian waste-stream. Herein, five waste categories were considered
109 in this study: glass, vehicles, waste electrical and electronic equipment (WEEE), plastics, and
110 combustibles. These waste categories undergo sorting and defragmenting, where subfractions are
111 sent to be either landfilled, incinerated or recycled. During incineration waste is transformed to
112 gases, fly ash and bottom ash. In Norway, fly ash is landfilled as hazardous waste, and bottom ash
113 undergoes metal recycling followed by landfilling as normal waste. All waste treatments produce
114 atmospheric emissions or water leachate. Water leachate can be emitted directly to the
115 environment, or be treated by a water treatment plant (WTP), which would emit treated water and
116 sludge.

117 There are three ways that waste and BPA mass can exit the system boundaries presented
118 in Figure 1; i) thermal-destruction through incineration, ii) the export of recycled/recyclable
119 materials, and iii) environmental emissions in the form of air, water and WTP sludge. New
120 products from recycled materials are considered to be outside the system boundaries. Further,
121 products of WTP sludge, which in Norway includes biogas and soil fertilizer, are also considered
122 outside the system boundaries. The only way for BPA to be stored as a "stock" in the MFA is by
123 landfilling.

124 The MFA was conducted with annual emissions as the functional unit by using Microsoft Excel
 125 2013 and STAN (subSTance flow ANalysis) Version 2.5.1072 (Vienna University of Technology,
 126 <http://www.stan2web.net/>).

127

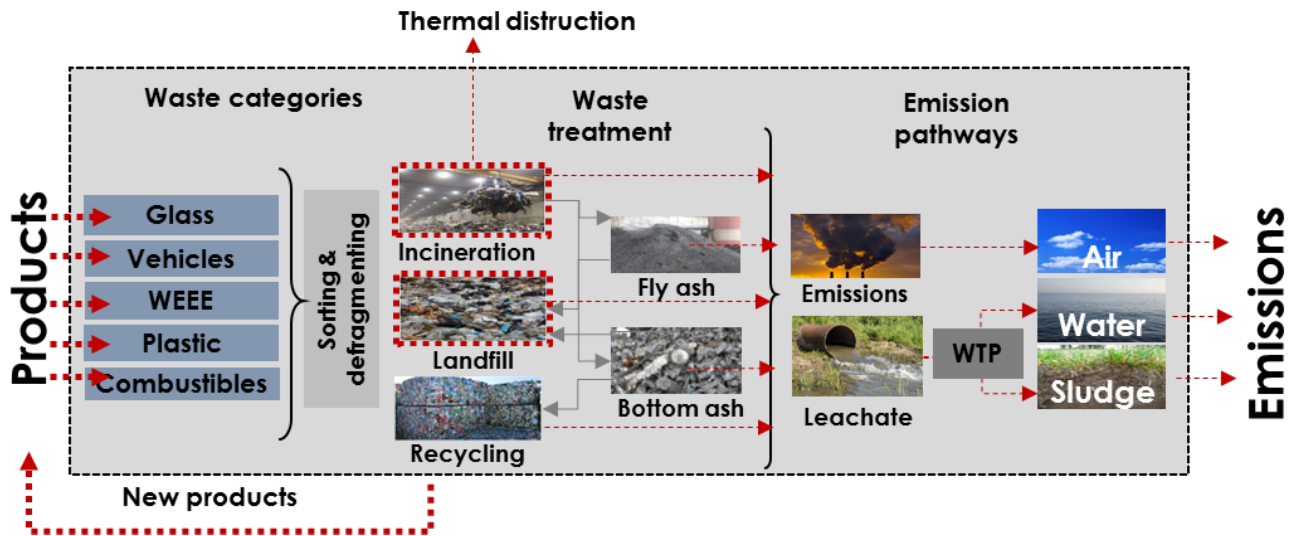

128

129 **Figure 1. System boundaries for the material flow analysis (MFA). The mass of waste and its**
 130 **bisphenol A are distributed through the various processes from left-to-right. Dotted lines**
 131 **represent removal pathways from the system**

132

133 2.2 Waste categories

134 The five waste categories considered in this study and their subfractions are defined in Table 1..

135 The quantities presented in this table are the total Norwegian mass flow of all waste sources

136 (household, manufacturing industries, construction, etc.) as defined by Statistics Norway

137 (www.ssb.no). These waste categories were selected based on data availability of both waste

138 statistics and BPA concentrations. In addition, targets to recycle more of these types of waste have

139 been set where for instance by 2030 the EU has a target of recycling 65% of municipal waste and

140 75% of packaging waste (EC, 2015a, c). One important BPA-containing waste stream that was

141 not included here was paper (and cardboard) waste sorted for recycling as we did not have access

142 to paper recycling facilities. The concentrations and mass flows of BPA in paper recycling in

143 Denmark was recently the focus of series of papers by Pivnenko et al. (Pivnenko et al., 2015a;
144 Pivnenko et al., 2016a; Pivnenko et al., 2016b; Pivnenko et al., 2015b). Therefore, the results of
145 Pivnenko et al. will be discussed alongside ours, in order to include this important waste stream..

146 The waste categories we selected also contain subfractions that, for the purposes of the MFA,
147 are categorized as being either unique or composite. A unique waste fraction is one in which both
148 mass flow statistics and a BPA concentrations (e.g. recycled glass, composite glass, cable plastic,
149 etc.) could be obtained. A composite waste fraction is one that is of general interest, enough to
150 warrant inclusion in the MFA, but a fraction that consists of different unique fractions. For
151 instance, in order to carry out emissions estimates for the composite fraction "vehicle waste", the
152 sum of its unique waste fractions: "coarse fluff", "fine fluff", "lead batteries" and "other (metal)"
153 was taken. In this manner, scenarios can be implemented in the MFA on both unique and composite
154 waste fractions, such as "recycle all coarse vehicle fluff" or "recycle all vehicle waste",
155 respectively, in order to estimate the impact on environmental emissions.

156 **Table 1. Approximate mass of diverse waste fractions generated in Norway for the year 2011 (\dot{m}_{waste}) along with the relative mass**
 157 **percentages recycled f_{recycled} , landfilled $f_{\text{landfilled}}$, incinerated, $f_{\text{incinerated}}$, and incombustible after incineration, f_{incom} .**

| Group | Fraction | Fraction ID and Definition | Type ^{a)} | \dot{m}_{waste} (kilotons/year) | f_{recycled} (%) | $f_{\text{landfilled}}$ (%) | $f_{\text{incinerated}}$ (%) | f_{incom} ^{b)} (%) | Notes |
|---------|-------------------------|--|--------------------|---|------------------------------|--------------------------------|---------------------------------|---|-------|
| Glass | Recycled glass | (1) Glass that is sorted for recycling | unique | 100 ± 11 | 100.0 | 0.0 | 0.0 | 100 | c |
| | Composite glass | (2) All other glass | unique | 114 ± 13 | 0.0 | 7.2 | 92.8 | 100 | c |
| | All glass | (3) = (1) + (2) | comp. | 214 ± 17 | 46.7 | 3.9 | 49.4 | 100 | |
| Vehicle | Coarse Fluff | (4) Non-metallic automobile shredder residue (ASR) > 8 mm | unique | 23 ± 3 | 0.0 | 0.0 | 100.0 | 20 | d,e |
| | Fine Fluff | (5) ASR between 2 – 8 mm | unique | 9 ± 1 | 10.0 | 90.0 | 0.0 | | d,e |
| | Lead batteries | (6) | unique | 13 ± 1 | 100.0 | 0.0 | 0.0 | | f |
| | Other (metal) | (7) Other materials (metal, glass, etc.) | unique | 94 ± 11 | 100.0 | 0.0 | 0.0 | | d |
| | All vehicle | (8) = (4) + (5) + (6) + (7) | comp. | 140 ± 11 | 77.5 | 5.7 | 16.8 | 3.2 | |
| WEEE | Remaining plastic | (9) WEEE plastic that is not cable plastic or BFR plastic | unique | 48 ± 5 | 85.5 | 6.9 | 7.6 | 0.5 | g, h |
| | BFR plastic | (10) WEEE plastic separated for containing BFRs | unique | 2 ± 0 | 0.0 | 0.0 | 100.0 | 0.5 | g, i |
| | Cable Plastic | (11) Plastic stripped from cables | unique | 15 ± 2 | 91.5 | 1.6 | 6.8 | 0.5 | j |
| | Remains / Metal | (12) Other materials (metal, glass, etc.) | unique | 80 ± 9 | 84.2 | 5.5 | 10.3 | 20 | k |
| | All WEEE | (13) = (9) + (10) + (11) + (12) | comp. | 145 ± 11 | 84.2 | 5.5 | 10.3 | 11 | k |
| Plastic | Packaging plastic | (14) Plastic separated for potential recycling | unique | 194 ± 22 | 60.1 | 1.3 | 38.6 | 0.5 | g, l |
| | Composite, other | (15) Plastic in non-sorted wastes, excluding WEEE&vehicles | unique. | 207 ± 23 | 0.0 | 8.1 | 91.9 | 0.5 | g, l |
| | Composite, WEEE&vehicle | (16) = (9) + (10) + (11) + 0.6(4) + 0.3(5) | comp. | 82 ± 9 | 67.2 | 7.3 | 25.5 | 0.5 | g, l |
| | All plastic | (17) = (14) + (15) + (16) | comp. | 482 ± 33 | 35.6 | 5.2 | 59.2 | 0.5 | c |
| Comb. | All combustibles | (18) All waste combusted in Norway | comp. | 1326 ± 150 | 0.0 | 0.0 | 100.0 | 16 | c,m |
| | Considered combustibles | (19) = 0.494(3) + 0.168(8) + 0.103(13) + 0.386(14) + 0.919(15) | comp. | 409 ± 46 | 0.0 | 0.0 | 100.0 | 28 | c,m |
| | Remaining combustibles | (20) = (18) – (17) | unique | 917 ± 156 | 0.0 | 0.0 | 100.0 | 11 | c,m |

158 WEEE = Waste of electrical or electric equipment; BFR = brominated flame retardants; a) unique indicates a unique waste fraction, composite indicates if it is a combination of diverse
 159 waste fractions from this table; b) fraction of incinerated waste that becomes ashes (i.e. % ash = $f_{\text{incinerated}} \times f_{\text{incom}}$), see the SI Table S1, c) Data from Statistics Norway (Statistisk sentralbyrå)
 160 for 2011 accessed December 2014 from <http://www.ssb.no/>; d) Mass estimates from Autoretur AS (<http://www.autoretur.no/gjenvinning-av-metaller-gir-stor-energi-og-miljogevinst/>,
 161 accessed January 2015); e) Fraction estimates based on personal communication with the company Norsk Gjenvinning June 2014, note that this does not include metals in the fluff that
 162 are recycled post incineration; f) (Agency, 2012a) data for 2009; g) (Agency, 2012b); h) Based on a 2010 estimate of plastic in WEEE minus the reported mass flow for cable plastic and
 163 BFR plastic; i) BFR plastics are not allowed to be recycled under RoHS; j) 60% of cable plastic is handled in Norway for sorting, 40% sent abroad, this study assumes 100% of cable plastic
 164 is handled in Norway; k) Data from (EE-registeret, 2012); l) percentages are based on mass balance calculations, assuming 60% of coarse fluff is plastic and 30% of fine fluff is plastic,
 165 based on fluff typically containing 40% plastic and fine fluff containing more wood and stone grains; m) many of the considered combustible fractions (E.g. WEEE, vehicle combustibles)
 166 are incinerated abroad, as Norway incinerates primarily municipal waste, though in this study we are assuming they are incinerated in Norway (in reality the "considered combustibles" is
 167 lower and "remaining combustibles" is higher, relative to "All combustibles").

168 2.3 Waste treatment

169 Table 1 shows estimates of the total yearly production of waste, \dot{m}_{waste} (kilotons/y), for the
170 different waste fractions alongside relative mass percentages for waste that is recycled (f_{recycled}),
171 landfilled ($f_{\text{landfilled}}$) and incinerated ($f_{\text{incinerated}}$). These data are based on national statistics, industry
172 reports as well as personal communication with industry representatives (see the footnotes to Table
173 1). The majority of data is for the year 2011, or as close to 2011 as possible, as this was the most
174 recent year that complete national statistics were available.

175 Regarding ashes produced by waste incineration, one study estimated the total wet mass of
176 bottom and fly ash to be 20 – 40 % and 3 – 8 % of the original waste mass, respectively (Sabbas
177 et al., 2003). According to Norwegian Statistics (www.ssb.no/en/avfhand/) in 2011 the mass of
178 "incineration residues" (bottom and fly ash) was approximately 16% of the total mass incinerated
179 in Norway, which is on the low end of the literature estimate. This is possibly due to the the
180 exportation of less-calorific combustible fractions to Sweden, where the demand is higher
181 (Naturvårdsverket, 2012). Based on these considerations, the fraction of waste sent to incineration
182 that is incombustible, f_{incom} , was derived (Table 1) and was further subdivided to landfilled fly ash,
183 landfilled bottom ash and recycled bottom ash (i.e the metallic fraction of bottom ash); see Section
184 S1 of the Supplementary Material for further details.

185

186 2.4 Emission pathways

187 2.4.1 Dust and suspended solid concentrations

188 To obtain information related to release pathways of BPA as it is being handled throughout
189 the waste stream, a combination of field measurements and existing data were utilized. In a
190 previous study, BPA was analyzed in air, leachate water and waste from 12 waste-handling
191 facilities located in southeastern Norway from mid-2013 to mid-2014 (Morin et al., 2015).

192 Concentration data used from this study are presented in Table 2. Three of the sampled facilities
193 were landfills, each containing various quantities of municipal and industrial waste, digested WTP
194 sludge for composting (i.e. digestate, which is landfilled temporarily before being deployed in
195 agriculture), bottom ash and fly ash. Seven of the sampled locations were sorting and
196 defragmenting facilities for WEEE and/or vehicle waste. The remaining two sampled facilities
197 were for sorting and incinerating combustible waste (one municipal and one industrial). With the
198 exception of one combustible waste facility and one WEEE/vehicle facility, all the facilities were
199 in rural environments and represent the likely key source of BPA in the area. For the other sites,
200 sampling was done very close to the sources (e.g. air sampling near the shredder or vents), to
201 minimize the influence from other sources of BPA. This previous study also discussed partitioning
202 mechanisms of BPA from waste to air and water, showing that BPA primarily is in the particle
203 phase in air and the dissolved phase in water (Morin et al., 2015). Additionally, concentrations of
204 BPA in 46 landfill leachates, 34 WTP effluents, and 34 WTP sludge samples were taken from a
205 report compiling data from 2002 – 2012 in Norway (Section S2 in the Supplementary Material)
206 (Arp, 2013).

207

208 **2.4.2 Emission Factors**

209 Emission factors (EF) were used to estimate particulate and BPA emissions from waste-handling
210 processes to the atmosphere and leachate. The EF for dust to the atmosphere, EF_{dust} , was defined
211 as:

212

$$213 \quad EF_{\text{dust}} (\text{tons}_{\text{dust}}/\text{tons}_{\text{waste}}) = \dot{m}_{\text{dust}} / \dot{m}_{\text{waste}} \quad (1)$$

214

215 where \dot{m}_{dust} is the mass flow of atmospheric dust emissions ($\text{tons}_{\text{dust}}/\text{y}$) originating from waste and
 216 no other sources (e.g. diesel dust, brake dust, ambient dust) that is transported away from a facility.
 217 Atmospheric emissions of BPA occur mainly via BPA-bound to dust (Morin et al., 2015), and thus
 218 emission factors of BPA emitted into air per mass of waste at a specific type of facility, $EF_{\text{air,BPA}}$
 219 ($\text{kg}_{\text{BPA}}/\text{kg}_{\text{waste}}$), were derived as follows:

220

$$221 \quad EF_{\text{air,BPA}} = \dot{m}_{\text{dust}} C_{\text{dust,BPA}} / (1000 \text{ kg}_{\text{waste}}/\text{tons}_{\text{waste}} \times \dot{m}_{\text{waste}}) \quad (2)$$

222

223 where $C_{\text{dust,BPA}}$ is the BPA concentration measured in the dust particles ($\text{kg}_{\text{BPA}}/\text{kg}_{\text{dust}}$) produced
 224 by a waste treatment process.

225

226 Similarly, an EF for suspended solid in leachate, EF_{ss} , can be defined:

227

$$228 \quad EF_{\text{ss}}(\text{tons}_{\text{ss}}/\text{tons}_{\text{waste}}) = \dot{m}_{\text{ss}} / \dot{m}_{\text{waste}} \quad (3)$$

229

230 where \dot{m}_{ss} is the mass flow of suspended solids in leachate ($\text{tons}_{\text{ss}}/\text{y}$). For this analysis, EF_{ss} is
 231 predominantly used to assess the amount of suspended solids that end up in WTP from waste-
 232 handling. Suspended solids in leachate only contain a negligible amount of BPA compared to the
 233 amount dissolved in water, except at extreme particulate concentrations (Morin et al., 2015). The
 234 facility specific EF of BPA in leachate per mass of waste, $EF_{\text{leachate,BPA}}$ ($\text{kg}_{\text{BPA}}/\text{kg}_{\text{waste}}$), were
 235 derived based on the flow rates of leachate Q_{leachate} (L/y)

236

$$237 \quad EF_{\text{leachate,BPA}} = Q_{\text{leachate}} C_{\text{BPA_Leachate}} / (1000 \dot{m}_{\text{waste}}) \quad (4)$$

238

239 where $C_{\text{BPA_Leachate}}$ ($\text{kg}_{\text{BPA}}/\text{L}$) is the total leachate concentration.

240 Data to derive \dot{m}_{dust} and \dot{m}_{ss} were taken from a compilation of dust and leachate
241 measurements at sampled facilities (Morin et al., 2015), complemented by data from other landfills
242 and annual reports from Norwegian waste-to-energy plants, as presented in Section S3
243 (Supplementary Material). $EF_{\text{air,BPA}}$ and $EF_{\text{leachate,BPA}}$ for the whole of Norway were derived by
244 using the average of available $C_{\text{dust,BPA}}$, and $C_{\text{BPA_Leachate}}$ for a specific type of waste or waste-
245 handling facility for which data were available in combination with estimated national values for
246 Q_{leachate} and \dot{m}_{waste} (see Section S3).

247

248 **2.4.3 Mass flow modelling**

249 The mass flow of BPA in waste entering the waste stream for sorting and defragmenting
250 (SD), $\dot{m}_{\text{SD_BPA}}$ ($\text{kg}_{\text{BPA}}/\text{y}$) was determined by multiplying the relevant \dot{m}_{waste} and the corresponding
251 waste BPA concentration $C_{\text{waste,BPA}}$ ($\text{kg}_{\text{BPA}}/\text{kg}_{\text{waste}}$) (Table 2):

252

$$253 \quad \dot{m}_{\text{SD_BPA}} = \dot{m}_{\text{waste}} C_{\text{waste,BPA}} \quad (5)$$

254

255 A similar equation was used to account for bottom ash, \dot{m}_{BA} , and fly ash, \dot{m}_{FA} , being transferred
256 from the incinerator to landfill (e.g. $\dot{m}_{\text{landfilled ash,BPA}} = \dot{m}_{\text{BA}} C_{\text{BA,BPA}}$, where $C_{\text{BA,BPA}}$ is the
257 concentration of BPA in bottom ash). To calculate BPA in waste being incinerated, $\dot{m}_{\text{I_BPA}}$,
258 landfilled $\dot{m}_{\text{L_BPA}}$ and recycled $\dot{m}_{\text{RE_BPA}}$, which occurs after sorting and defragmenting (Figure 2),
259 an equation that accounts for losses to the environment during sorting and defragmenting was used
260 as follows, using incineration as an example:

261

262
$$\dot{m}_{I_BPA} \text{ (kg}_{BPA}/y) = (\dot{m}_{SD_BPA} - EF_{SD_BPA,dust} - EF_{SD_BPA,leachate}) f_{incinerated} \quad (6)$$

263

264 where $EF_{SD_BPA,dust}$ and $EF_{SD_BPA,leachate}$ (kg_{BPA}/kg_{waste}) are emissions factors for air and leachate,
265 respectively, from the initial sorting and defragmenting. In this manner, emission factors from
266 waste that is incinerated ($EF_{I_BPA,dust}$ and $EF_{I_BPA,leachate}$), landfilled ($EF_{L_BPA,dust}$ and
267 $EF_{L_BPA,leachate}$) and recycled ($EF_{RE_BPA,dust}$ and $E_{RE,BPA,leachate}$) were estimated for the unique waste
268 categories.

269 To derive total BPA mass flows for "composite waste" and "all waste" categories (Table
270 1), \dot{m}_{BPA} values (including \dot{m}_{SD_BPA} , \dot{m}_{I_BPA} , etc.) and EF_{BPA} values ($EF_{I_BPA,dust}$, $E_{RE,BPA,leachate}$
271 etc.) were added based on the individual waste fractions they contained. For instance, for the waste
272 category "considered combustibles" the \dot{m}_{BPA} values for glass, vehicle fluff, WEEE and plastic
273 sorted for incineration were added together.

274 To derive the amount of BPA that was emitted as water or sludge from WTP,
275 $EF_{WTP_BPA,water}$, and $EF_{WTP_BPA,sludge}$, the ratio of the average concentration of BPA in Norwegian
276 WTP effluent 0.923 µg/L and sludge 0.536 µg/g (Arp, 2013) (see also Section S3, supplementary
277 material), was used to derive a log (C_{sludge}/C_{water}) ratio of 2.5.

278

279 **2.5 Assumptions in the mass flow analysis**

280 Certain simplifying assumption for the MFA were made. The first assumption is that all
281 sorting, landfilling, incineration and initial recycling is handled in Norway, despite substantial
282 quantities of Norwegian waste being shipped abroad for handling. As examples, for Norwegian
283 WEEE 29% is handled in the EU and 16% outside the EU (EE-registeret, 2012), and for
284 combustibles large amounts are exported to Sweden for incineration (Naturvårdsverket, 2012).

285 Regarding recycling, only "initial recyclable processing" is considered in the MFA, as in Norway
286 we could find very few facilities that utilize recycled materials from the selected waste fractions
287 for manufacture into new products. "Initial recyclable processing" herein refers to the grinding and
288 reclamation of recyclable waste, such that it becomes a raw material (e.g. plastic chips or flakes,
289 crushed glass, metal scrap) ready for smelting and remanufacture into new products, abroad. As a
290 conservative assumption, emissions from "initial recyclable processing" were assumed to be twice
291 that measured in Norwegian WEEE/Vehicle sorting and defragmenting facilities, as these facilities
292 generally performed initial sorting and grinding. It is assumed that no processes that specifically
293 add or remove BPA occurs during "initial recyclable processing".

294 The second group of assumptions relate to water leachate. Firstly, it is assumed leachate
295 from "Defragmentation and Sorting", "Incineration" and "Initial Recyclable Processing" facilities
296 are transported by a sewage system to a municipal WTP, and not emitted directly into the
297 environment. This assumption was not applied to "Landfills", as it is documented that the leachate
298 from 45% of Norwegian landfills directly enters the environment after on site treatment, and the
299 remaining 55% is transported to a municipal WTP (Okkenhaug and Arp, 2012). To be
300 conservative, it was assumed that no losses of BPA occurred during transport to the WTP or within
301 the WTP, despite BPA having a half-life in sludge of 2.5 to 4 days (Staples et al., 1998) and that
302 certain WTP processes can remove BPA (Fuerhacker, 2003); thereby such degradation was
303 assumed to occur after sludge was removed from the WTP (outside the MFA boundaries).

304 The third set of assumptions is related to stocks and losses during the waste-handling
305 processes. Waste or BPA mass that is sent to incineration and is converted by thermal destruction
306 to gases (e.g. CO₂) is mass that is lost from the system; whereas, mass isolated in landfills is
307 accumulated as a stock without further decomposition (BPA is considered stable in landfills under

308 anaerobic conditions (Limam et al., 2013)). The stock of BPA during defragmentation and sorting,
309 as well as initial recyclable processing, is set to zero (thus no degradation or stocking is considered
310 to occur). In the case of paper recycling, it is noted that BPA could be potentially removed or even
311 added during the recycling process, depending on the process and the desired recycled product
312 (Pivnenko et al., 2016a); however similar information for the waste fractions considered here could
313 not be found.

314 The fourth assumption is related to using input from or close to the year 2011 as being
315 representative, which in the case of landfills does not account for emissions originating from
316 stocked, landfilled waste from previous years, when landfilling was more prevalent than in 2011.
317 This will bias the presented EF_{landfill} leachate values for 2011 waste to be higher than the actual
318 value.

319

320 **2.6 Uncertainty Assessment in the mass flow analysis**

321 MFA are inherently uncertain. In addition to requiring several assumptions, they are based
322 on measured, estimated or extrapolated input parameters, such as mass estimates or concentrations,
323 each with their own uncertainties. This study adopted the uncertainty approach described in Laner
324 et al. (Laner et al., 2015). In this approach, data quality is evaluated in terms of its reliability,
325 completeness, temporal correlation, geographical correlation and other correlations; and based on
326 this evaluation, a coefficient of variation (CV) is assigned. CV values for input parameters are then
327 propagated through the mass-flow model. The CV values for the input parameters of this MFA,
328 and more information on the uncertainty analysis, are described in Section S6 (supplementary
329 material).

330

331

332 **2.7 Regional exposure outside the mass flow analysis**

333 The MFA primarily predicts local (immediate) emissions, and does not account for regional
334 impacts once BPA enters the environment. Therefore, measured BPA concentrations in the general
335 Norwegian population and environment that would arise from the estimated waste emissions were
336 predicted using CoZMoMAN (Breivik et al., 2010), a dynamic and non-spatially resolved linked
337 model which simultaneously predicts the behaviour of organic contaminants in both the physical
338 environment (CoZMo-POP2 (Wania et al., 2006)) and in the human food chain (ACC-Human
339 (Czub and McLachlan, 2004)). In brief, CoZMoMAN requires three different types of model input
340 parameters: (i) data describing environmental and food-chain characteristics, along with data
341 representing the simulated chemical, (ii) chemical property data, and (iii) emission data. The
342 number of input data required to describe environmental and food-chain characteristics (i) far
343 exceeds the chemical property and emission input data specific for this study (ii and iii). This
344 model was selected as it has previously been parameterized for the Nordic region (mainly Sweden,
345 Norway and Denmark), reflecting relevant food-chains, environmental and climatic conditions; it
346 has also been evaluated with respect to its capability to reproduce observations of both
347 polychlorinated biphenyls (PCBs) (e.g. Breivik et al., 2010) and short-chain chlorinated paraffins
348 (SCCPs) (Krogseth et al., 2013). These evaluations have shown agreement between modelled data
349 and measurements within a factor of 2 to 4 in the case of individual PCBs and within a factor 6 for
350 SCCPs. As the CoZMoMAN model is parameterized to cover Sweden and Denmark in addition
351 to Norway, a similar per capita emission rate in the other countries as for Norway was assumed.
352 This was done by accounting for the population of each country living within the domain, using
353 an identical mode of emissions released to air, fresh water and agricultural soil (via the deposition
354 of WTP sludge as fertilizer, while assuming no BPA loss as a conservative assumption).

355 There is therefore the following implicit assumptions in the regional exposure model. The
356 first is that the current parameterisation for the Nordic region represents a reasonable
357 approximation for Norway alone. The second is that there was no net exchange of BPA across the
358 CoZMoMAN model boundaries (i.e. the model domain was surrounded by an equally
359 contaminated region). The third is that the MFA output represents Norwegian emissions from
360 waste-handling, including the WTP sludge value is representative for the amount of BPA applied
361 to soils.

362 The property data compiled and used to simulate BPA concentrations using CoZMoMAN
363 are summarized in Section S7 (supplementary material).

364

365 ***2.8 Management scenarios***

366

367 After establishing the MFA for the current situation of Norwegian waste handling, the MFA was
368 manipulated to assess the potential impact of alternative waste management scenarios on
369 emissions. Following the waste hierarchy as outlined by European Commission directive
370 2008/98/EC (waste framework directive), the preferable management strategies for waste
371 management in decreasing order are: 1) prevention, 2) preparing for re-use, recycling, 3) other
372 recovery (including energy recovery by incineration), and 4) disposal (i.e. landfilling). With this
373 in mind, four different alternative scenarios for BPA mitigation were considered.

374 *Scenario 1 Prevention.* This scenario models the outcome of Norwegians producing less BPA-
375 containing waste; here by an ambitious target of 50%. This was modelled in the MFA indirectly
376 by multiplying all measured BPA concentrations by 0.5, such that the mass flow entering the waste
377 stream would be reduced by 50%. In addition to waste prevention, this scenario also reflects the
378 case that the concentration of BPA in all waste materials was halved homogenously in

379 concentration across all considered waste fractions, yet the mass flow of waste was not changed,
380 and thus reflects a potential (and extreme) decrease in demand for BPA (such as by a phase-out,
381 or by replacing to another substance).

382 *Scenario 2 Recycling.* In this scenario vehicle fluff, WEEE and plastic that was incinerated in
383 the original MFA is sent for initial recyclable processing instead, and no change is made to the
384 amount directly landfilled (though the amount of incineration ashes landfilled is changed
385 correspondingly). This is a relatively extreme shift in waste-management practices, considering
386 that current targets for the transition towards a circular economy only target municipal and
387 packaging waste (EC, 2015b, c). This was modelled by setting all $f_{\text{incinerated}}$ to 0 in Table 1 for
388 WEEE, vehicles and plastics, and adjusting f_{recycled} accordingly.

389 *Scenario 3 Incineration.* In this scenario, all non-ash waste that is currently landfilled directly is
390 incinerated before landfilling as ashes; regardless of calorific value. This scenario was modelled
391 by setting $f_{\text{landfilled}}$ values in Table 1 to 0, and correspondingly increasing $f_{\text{incinerated}}$ values. No
392 change was made to f_{recycled} .

393 *Scenario 4 Landfilling of vehicle fluff.* Finally, to consider a scenario that goes contra to the
394 waste-hierarchy, in this scenario all vehicle fluff is landfilled instead of incinerated. This scenario
395 was chosen as in Scandinavia coarse fluff is incinerated and fine fluff is landfilled (Table 1), but
396 in many non-Scandinavian countries, vehicle fluff is commonly landfilled (Gerrard and Kandlikar,
397 2007; Santini et al., 2012). This was modeled setting the $f_{\text{landfilled}}$ values in Table 1 to 100% for
398 coarse and fine fluff, and f_{recycled} and $f_{\text{incinerated}}$ to 0.

399

400 **3 Results and discussion**

401 **3.1 Mass flow of waste**

402 Figure 2 presents the mass flow of the sum of glass waste, vehicle waste, WEEE, plastic
403 wastes and combustibles going through the Norwegian waste stream, as well as emissions into air,
404 water and sewage sludge. This MFA estimates that of the nearly 2 million tons/y of these wastes
405 that are generated in Norway, 567 tons/y are emitted as dust, 1038 tons/y as suspended solids in
406 water bodies, and 701 tons/y as WTP sludge sorted for biogas and fertilizer production.
407 Approximately 235 ktons/y of the selected waste are stored in landfills (as stock) and these consist
408 primarily of ashes, whereas 1116 kt/y are lost/destroyed via incineration. A further description of
409 Figure 2 is presented in Section S4 (Supplementary Material), along with an alternative version of
410 Figure 2 presenting uncertainties (which range from 11.3 to 60.1%).

411

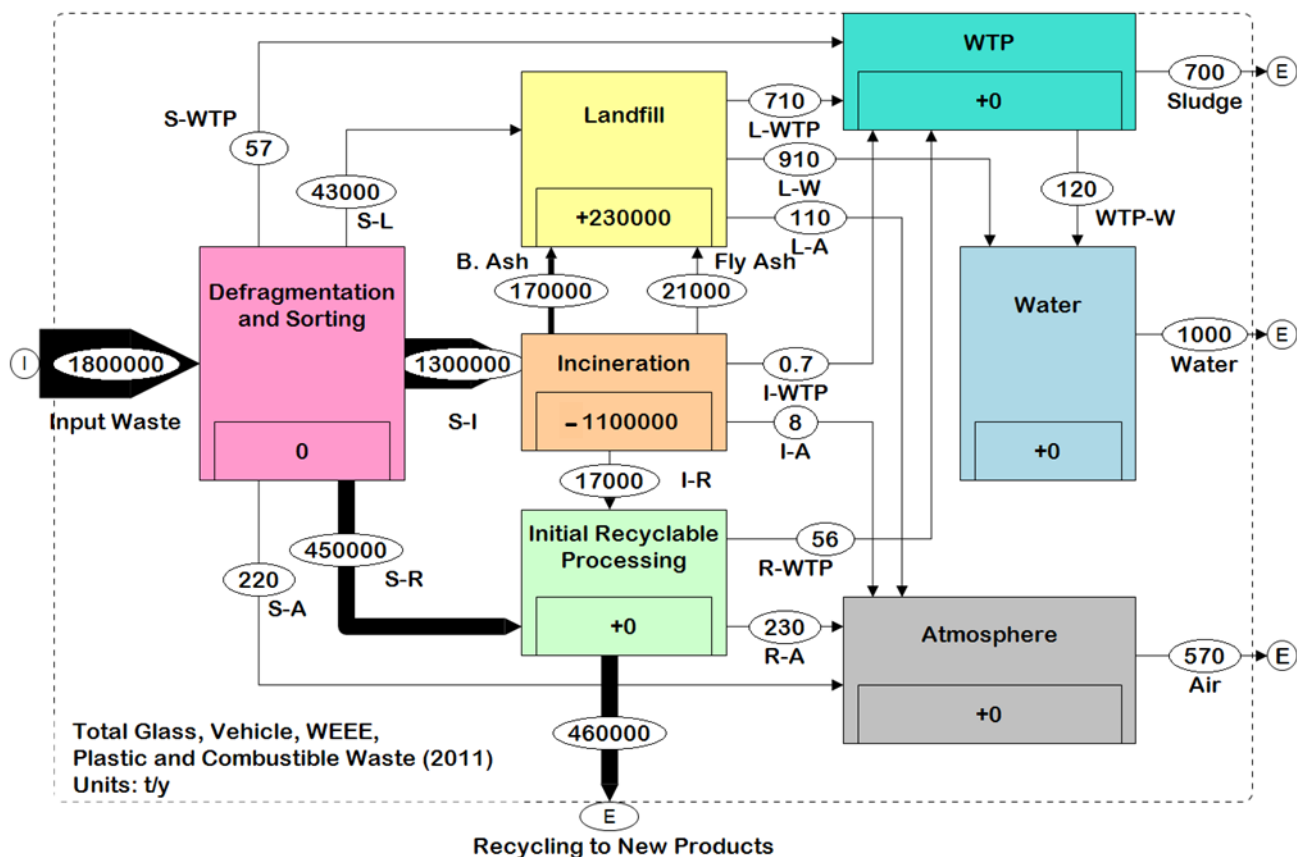

412

413 **Figure 2. Principle presentation of connections between the processes in the MFA of the sum of glass**
 414 **waste, combustibles, vehicle waste, WEEE and plastic wastes going through the Norwegian waste**
 415 **stream (collectively referred to as "Input Waste") as well as emissions into air, water and WTP sludge**
 416 **for the year 2011. All quantities have the units tons/y. Processes are given in boxes and flows as arrows**
 417 **connecting the processes. Symbols used in the chart include S (sorting and defragmentation), L**
 418 **(landfill), I (Incineration), R (Initial Recyclable Processing), WTP (water treatment plant), W**
 419 **(environmental water recipients), A (atmosphere), E (Recycling to New Products or Emissions).**
 420 **Numbers inside the processes Landfilling and Incineration indicate the mass that was lost or**
 421 **accumulated from waste stream due to thermal destruction (negative values) or long term isolation**
 422 **(positive values).**

423

424 3.2 BPA in the waste categories

425 Table 2 presents the mass flow of BPA for the sum of the five selected waste categories.

426 The largest mass flow is associated with the plastic waste, being responsible for 90631 kg/year, or
 427 98.5% of the total BPA in waste (91984 kg/y). Plastics can vary widely in their BPA content,
 428 where BPA is found abundantly in polycarbonate and epoxy (e.g. glue and coatings). One of the

429 most common types of plastic, PVC (polyvinylchloride), is also a source of BPA, including when
 430 it is used for food packaging (Lopez-Cervantes and Paseiro-Losada, 2003). Representatives from
 431 the Norwegian waste industry informed us that alternatives to incinerate PVC are often sought
 432 after, as the produced chloride gas during PVC incineration is corrosive in waste incinerators
 433 (Sadat-Shojai and Bakhshandeh, 2011). Of the BPA associated with plastic, 60% was estimated to
 434 be incinerated, 5% landfilled (e.g. fine vehicle fluff, some WEEE fractions) and 35% recycled.

435
 436 **Table 2. Concentrations and mass flows of BPA in different waste categories and fractions,**
 437 **undergoing different waste-handling processes**

| Fraction | $C_{\text{waste,BPA}}^{\text{a)}}$ | Type | $f_{\text{BPA,waste}}^{\text{b)}}$ | $\dot{m}_{\text{SD_BPA}}$ Sorting& Defragmentation | $\dot{m}_{\text{I_BPA}}$ Incineration | $\dot{m}_{\text{LA_BPA}}$ Landfilling | $\dot{m}_{\text{RE_BPA}}$ Recycling |
|---------------------------------------|------------------------------------|--------|------------------------------------|---|---|---|---|
| | $\mu\text{gBPA/kg}_{\text{waste}}$ | | (%) | ($\text{kg}_{\text{BPA}}/\text{y}$) | ($\text{kg}_{\text{BPA}}/\text{y}$) | ($\text{kg}_{\text{BPA}}/\text{y}$) | ($\text{kg}_{\text{BPA}}/\text{y}$) |
| Glass | | | | | | | |
| Recycled glass | 11.0 ± 7.1 | unique | 0.0% | 1.1 ± 0.7 | | | |
| Composite glass | 9.0 ± 2.8 | unique | 0.0% | 1.0 ± 0.3 | 0.9 ± 0.3 | 0.1 ± 0.0 | 0.0 ± 0.0 |
| All glass | 9.9 ± 5.5 | comp. | 0.0% | | 0.9 ± 0.3 | 0.1 ± 0.0 | 1.1 ± 0.3 |
| Vehicle^{c)} | | | | | | | |
| Coarse Fluff | 4818.8 ± 1311.2 | unique | 0.1% | 113.0 ± 33.3 | 111.6 ± 33.2 | 0.0 ± 0.0 | 0.0 ± 0.0 |
| Fine Fluff | 10914.4 ± 6983.7 | unique | 0.1% | 96.9 ± 62.9 | 0.0 ± 0.0 | 86.7 ± 25.8 | 9.6 ± 2.9 |
| Vehicle Fluff | 6492.1 ± 3350.1 | comp. | 0.2% | 209.9 ± 109.6 | 111.6 ± 33.2 | 86.7 ± 25.8 | 9.6 ± 2.9 |
| WEEE | | | | | | | |
| Remaining plastic | 200499 ± 122465 | unique | 10.5% | 9630 ± 5981 | 735 ± 219 | 663 ± 197 | 8227 ± 2446 |
| BFR plastic | 84430 ± 27958 | unique | 0.2% | 169 ± 59 | 169 ± 50 | 0 ± 0 | 0 ± 0 |
| Cable Plastic | 29087 ± 19357 | unique | 0.5% | 435 ± 294 | 30 ± 9 | 7 ± 2 | 397 ± 118 |
| Remains / Metal | 1169 ± 301 | unique | 0.1% | 94 ± 26 | 9 ± 3 | 5 ± 1 | 73 ± 22 |
| All WEEE | 71188 ± 46656 | comp. | 11.2% | 10328 ± 6811 | 942 ± 280 | 675 ± 201 | 8697 ± 2586 |
| Plastic | | | | | | | |
| Packaging & comp ^{d)} | 200499 ± 122465 | unique | 42.3% | 80300 ± 49877 | 53052 ± 15774 | 3856 ± 1146 | 23392 ± 6955 |
| Comp. WEEE&vehicle | 126884 ± 79309 | comp. | 56.2% | 10331 ± 6562 | 1000 ± 297 | 696 ± 207 | 8627 ± 2565 |
| All plastic | 188052 ± 124720 | comp. | 98.5% | 90631 ± 60433 | 54052 ± 16071 | 4552 ± 1353 | 32020 ± 9520 |
| Combustibles | | | | | | | |
| Considered combustibles ^{e)} | 132766 ± 155648 | comp. | 60.2% | 54269 ± 63916 | 54269 ± 16136 | 0 ± 0 | 0 ± 0 |
| Remaining combustibles ^{e)} | 1248 ± 373 | unique | 1.2% | 1145 ± 394 | 1144 ± 340 | 0 ± 0 | 0 ± 0 |
| All combustibles | 41790 ± 30738 | comp. | 59.0% | 55413 ± 41236 | 55413 ± 16476 | 0 ± 0 | 0 ± 0 |
| Ashes | | | | | | | |
| Fly Ash | < LOQ | unique | | | | neg | |
| Bottom Ash | 235 ± 155 | unique | | | | 40 ± 12 | 4.0 ± 1.2 |
| Total | | | | | | | |
| All Waste | | | | 91984 ± 127812 | 55251 ± 16428 | 4617 ± 1373 | 32100 ± 9544 |

438 neg = negligible; LOQ = limit of quantification; italics = weighted averages for composite materials based on Table 1; unique
 439 =waste that remains as an unmixed fraction after sorting and defragmenting, such as glass-materials or plastic-materials sorted for
 440 recycling; comp. = waste mixtures of fractions that are either not separated during waste treatment, or were combined for this study
 441 due to not enough data being available to subdivide the fraction further. , a) concentrations presented in a previous study (Morin et
 442 al., 2015); b) the relative fraction of BPA in the specific waste fraction vs the total yearly produced BPA in the selected waste
 443 fractions entering Norwegian waste streams, c) vehicle metals and lead batteries are not included as they are assumed to have little
 444 BPA; d) due to lack of data on Packaging and Composite plastics, we assumed these were both the same as the "WEEE remaining
 445 plastic" concentration, which was for pooled "plastic fluff" samples from WEEE/Vehicle facilities, not including isolated BFR and
 446 cable plastics; e) considered combustibles referred to those already presented in the table (glass, vehicle fluff and plastic)

447

448 The mass flow of BPA in glass, vehicle fluff and "remaining combustibles" is very small
449 compared to plastics. This was expected for glass based on the low concentrations found in glass
450 ($11.0 \pm 7.1 \mu\text{g/kg}$). Vehicle fluff has relatively low BPA concentrations (from 4819 ± 1311 to
451 $10914 \pm 6984 \mu\text{g/kg}$) as well as \dot{m}_{waste} values (ca. 32 ktons/year) compared to packaging and
452 composite plastics ($200499 \pm 122465 \mu\text{g/kg}$ and ca. 482 ktons/year). However, the low BPA mass
453 and concentration ($1248 \pm 349 \mu\text{g/kg}$) and resulting mass flow (ca 1145 kg/y) in the "remaining
454 combustibles" fraction was not initially expected, due to the potential sources of BPA (like plastics
455 and paper waste (Fan et al., 2015)) that were visible within the analyzed samples. One potential
456 explanation for combustibles having a low BPA content is that BPA containing-paper and plastics
457 are removed by pre-sorting procedures prior to recycling. Pivnenko et al. (Pivnenko et al., 2016b)
458 found that a selection of individual waste paper and cardboard materials had a median of 20000
459 $\mu\text{g/kg}$ BPA (min 700 and max 4 800 000 $\mu\text{g/kg}$) in residual (non-sorted) waste paper, and 10000
460 $\mu\text{g/kg}$ BPA (min 530 and max 3 600 000 $\mu\text{g/kg}$) in source-segregated waste paper, with the
461 maximum concentrations being associated with receipts. This implies that a) the concentration for
462 combustibles in this study is on the low end compared to Danish waste-paper, b) source-
463 segregation would not on its own account for these low concentrations. Therefore, it could be that
464 these measured concentrations and mass flow estimates for BPA in remaining combustibles are
465 biased low, by up to an order of magnitude; though they would have to be biased low by two orders
466 of magnitude in order for the BPA mass flow to be similar to that of plastic..

467

468 **3.3 BPA in the waste treatment process**

469 Figure 3 presents the MFA of BPA in the selected waste categories through the entire
470 Norwegian waste stream (totaling 91984 kg/y) for the model year 2011. As presented in Figure 3,
471 *incineration* is estimated to remove the majority of BPA entering the waste stream (-55206 kg/y,

472 or 60%). BPA is known to be thermally unstable during waste incineration (Šala et al., 2010).
473 Considering the difference between the total amount of BPA in waste that was sorted for
474 incineration (-55251 kg/y), and the amount of BPA remaining in the bottom ash (40 kg/y) and fly
475 ash (0 kg/y), we estimate that 99.9% of BPA sorted for incineration was removed by this process.
476 Isolation due to *landfilling* accounted for accumulation of 4040 kg/y as stock in landfills, or 4% of
477 all BPA entering the waste stream. *Initial recyclable processing* is responsible for having a
478 potential of transferring up to 32076 kg/y, or 34% of the BPA into recyclables to be used for the
479 manufacture of new products. Depending on further processing of the recycled material, the
480 amount of BPA could be increased or decreased, which was not accounted for here. Some process
481 such as deinking paper waste are known to be able to decrease BPA concentrations (Pivnenko et
482 al., 2016a; Pivnenko et al., 2016b).

483

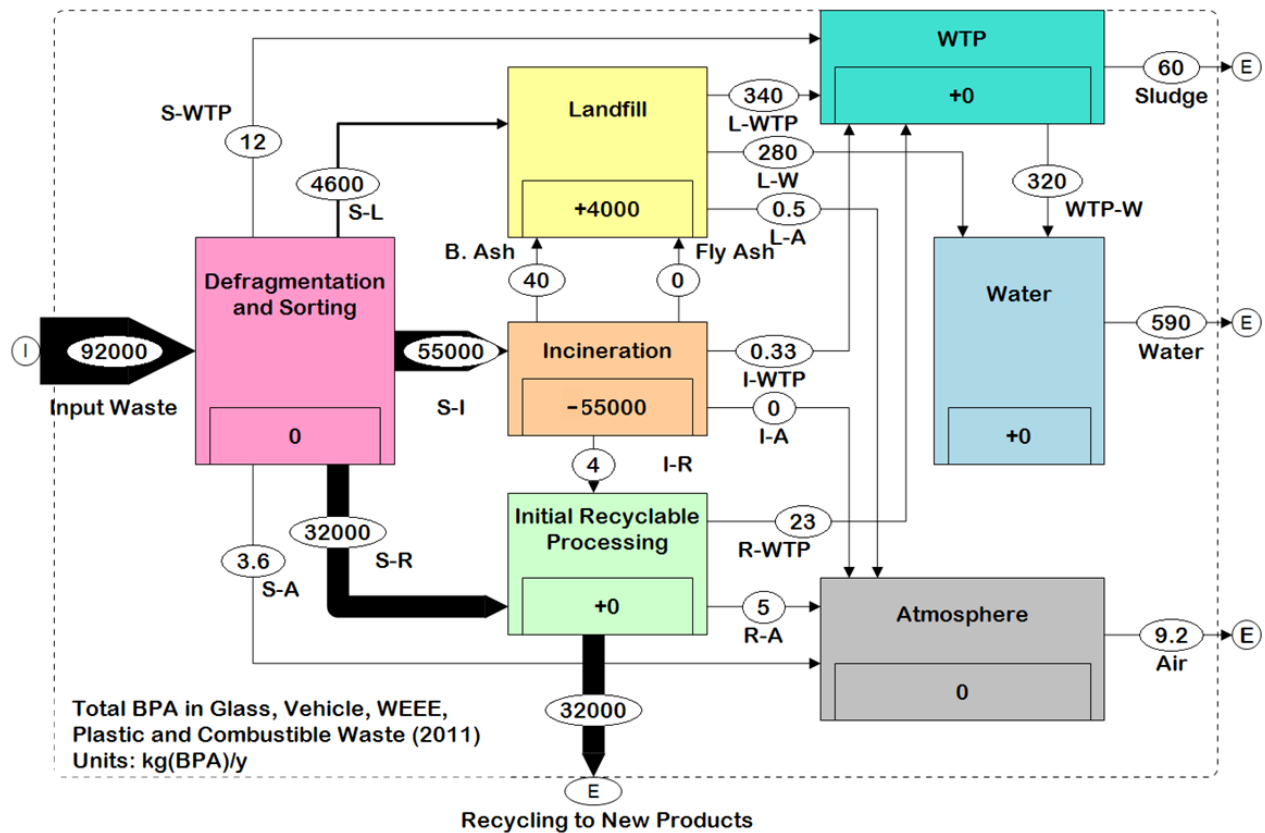

484

485 **Figure 3. Mass flow of BPA associated with glass waste, combustibles, vehicle waste, WEEE, and plastic wastes**
 486 **(collectively referred to as input waste) going through landfilling, incineration and initial recyclable processing**
 487 **in Norway. Symbols used in the chart are presented in Figure 2. Values along the arrows indicate the mass flow**
 488 **of waste and waste particles from one process to the next (see Table 2). All values are presented in the units**
 489 **kg/y. Numbers inside the processes Landfilling and Incineration indicate the mass that was lost or accumulated**
 490 **from waste stream due to thermal destruction (negative values) or long term isolation (positive values).**
 491

492 3.4 BPA emission pathways

493 As presented in Figure 3 and Section S5, the MFA estimates that 9 kg_{BPA}/y are emitted
494 from Norwegian waste handling as dust to the air phase, 593 kg_{BPA}/y are released into downstream
495 water bodies, and 60 kg_{BPA}/y end up in WTP sludge. The majority of water emissions are from
496 landfills. (340 kg/y to WTP and 278 kg/y to receiving waters). Therefore, considering most BPA
497 sent to landfills was associated with plastic (4552 kg of the total 4617 kg_{BPA}/y sent to landfills,
498 Table 2), the primary source of BPA emissions from the selected waste categories are plastic-
499 residues sent to landfills; though BPA-rich paper products (e.g. thermopaper) are another potential
500 source. Recall that the mass flow model inherently does not account for any historical reservoir in
501 landfills. Thus, the estimation herein of 134 g emission per kg landfilled BPA in 2011 (as derived
502 from values in Table 5) represents an upper limit, as the BPA emissions were from the aggregate
503 of several previous years of landfilling waste. Nevertheless it is clear from Figure 3 that landfilling,
504 by far, represents the waste handling process resulting in the largest emissions of BPA.

505 Figure 3 also estimates that a total of 364 kg_{BPA}/y enters WTPs (339 kg/y from landfilling
506 and 23 kg/y from initial recyclable processing). This value is slightly below the amount estimated
507 to enter all Norwegian WTPs of 408 kg_{BPA}/y (with 342 kg_{BPA}/y leaving in water and 64 kg_{BPA}/y
508 in sludge, Section S2). Taken together, this implies that the majority of BPA entering WTPs in
509 Norway may originate from landfill deposited plastic and paper waste. However, it should be kept
510 in mind that BPA can decompose in waste water, and this was not taken into account, therefore
511 the contribution of plastic in landfills presented here would represent an upper value.

512 As a basis of comparison for WTP emissions, a recent study (Yu et al., 2015) estimated
513 that country-wide WTP emissions in the USA for the year 2006/7 were 31800 kg_{BPA}/y in the water
514 phase and 2900 kg_{BPA}/y in the sludge phase. On a per capita bases (298.4 million in the USA, 2006
515 and 5.0 million in Norway, 2011), this equates to 1065 and 680 mg_{BPA}/capita/y for the water phase

516 in the USA and Norway, respectively; for the sludge phase this would be 10 and 13 mg_{BPA}/capita/y,
517 respectively. Thus, emission rates on a per capita basis are similar for these two countries (within
518 a factor of 1.6). A study of BPA in emissions from Korean WTPs found that total per capita
519 emissions were substantially lower for domestic WTP (16.1 mg_{BPA}/capita/y) than industrial WTP
520 (885 800 mg_{BPA}/capita/y) (Lee et al., 2015). Taken together, these studies imply that industry and
521 landfills are the two largest sources of BPA entering WTP and the aquatic environment.

522 There are several uncertainties regarding the estimations for initial recyclable processing
523 in Figure 3 and Table 2, based on the assumptions presented above. Firstly, because recycling of
524 plastic materials does not substantially occur in Norway, actual BPA emissions from initial
525 recyclable processing within Norway would be much less than presented in Figure 3. Further,
526 because recycling emissions can vary depending on the recycling process itself, and they were here
527 based on the assumption that they were twice the measured value that WEEE/Vehicle sorting and
528 defragmenting facilities as a conservative assumption (see Section 2.5 and Section S5 in the
529 supplementary material), recycling emissions are more uncertain than what this MFA presents. In
530 addition, outside of the model domain, BPA may be added or removed from recycled products
531 (Pivnenko et al., 2016a). Resolving this uncertainty is important to study further in follow-up
532 investigations, considering targets to recycle more types of plastic are increasing as part of the
533 shift to the circular economy (EC, 2015b).

534

535 **3.5 Regional exposure outside the mass flow analysis**

536 The CoZMoMAN model was used to predict the resulting regional exposure of BPA based on
537 Figure 3 emission estimates. The values are compared to observed regional exposure
538 measurements in Norway in Table 3. The sampling sites for the observed concentrations are
539 typically biased towards densely populated areas (e.g. Oslofjord, Lake Mjøsa, which are indeed

540 influenced by local waste-handling facilities and WTPs) while the model is not spatially resolved
 541 and therefore cannot reproduce any gradients in concentrations. Under these circumstances, one
 542 would therefore *a priori* expect CoZMoMAN to predict concentrations lower than measurements.

543
 544

545 **Table 3. Comparison CoZMoMAN model predictions for BPA and observations.**

| Environmental Media | Model (geomean) | Observed |
|---|----------------------------|-----------------|
| Marine sediment (ng/g _{dw}), Oslofjord ^{a)} | 2E-05 | <0.8-44 |
| Marine sediments (ng/g _{dw}), median, Norway ^{a)} | | 6.7 |
| Freshwater sediment (ng/g _{dw}), Lake Mjøsa ^{a)} | 0.01 | 2-3 |
| Freshwater sediment (ng/g _{dw}), median, Norway ^{a)} | | 8.4 |
| Cod liver (ng/g _{ww}) ^{a)} | 4E-05 | <0.3-1105 |
| Milk, Norway, 2012 (µg/L fresh weight) ^{b)} | 0.005 | <0.02 |
| Hamburgers, Norway, 2012 (µg/kg fresh weight) ^{b)} | 0.01 ^{d)} | 0.17 |
| Fish and fish products, Norway, 2012 (µg/kg fresh weight) ^{b)} | 4E-06 ^{e)} | 2.0 |
| Urine, pregnant women (mean age 30, mean conc. in µg/L) ^{c)} | 2E-08 ^{d)} | 4.5 |

546 a) (Thomas et al., 2014), b) (Sakhi et al., 2014), c) (Ye et al., 2009), d) Beef, assuming 15% (w/w) lipid content, e)
 547 Cod filet (all age classes), f) 30 year old pregnant women

548

549 Indeed, predicted BPA concentrations in humans and food from waste emissions are
 550 typically orders of magnitude lower than recent environmental measurements (Table 3). This
 551 suggests that the far-field human exposure of the general population to BPA arising from emissions
 552 within the waste sector is likely to be insignificant. This is in accordance with past findings
 553 suggesting that pathways other than far-field environmental exposures, such as the intake of
 554 canned food are more likely to control human exposure of Norwegians to BPA (Sakhi et al., 2014;
 555 Ye et al., 2009). However, as monitoring studies have confirmed, such as downstream from
 556 landfills (Morin et al., 2015) and urban-influenced environments (Table 3), BPA can be present in
 557 local environments at concentrations that are cause for concern regarding ecosystem health. As

558 further indication of this in other counties, residents near e-waste facilities in China had higher
559 levels of BPA in their urine than those in rural areas (Zhang et al., 2016).

560

561

562 **3.7 Management of bisphenol A in the waste stream**

563

564 The way in which the alternative waste-management scenarios (Scenario 1 – Prevention of waste
565 or BPA use, Scenario 2 – recycling all WEEE, plastic and vehicle waste currently incinerated,
566 Scenario 3 – incinerate waste currently landfilled and Scenario 4 – landfill incinerated vehicle
567 fluff) impact changes in sludge, water and air emissions (kg/y) is presented in Figure 4. Percentage
568 changes and corresponding raw data is presented in Section S8 (supplementary material).

569

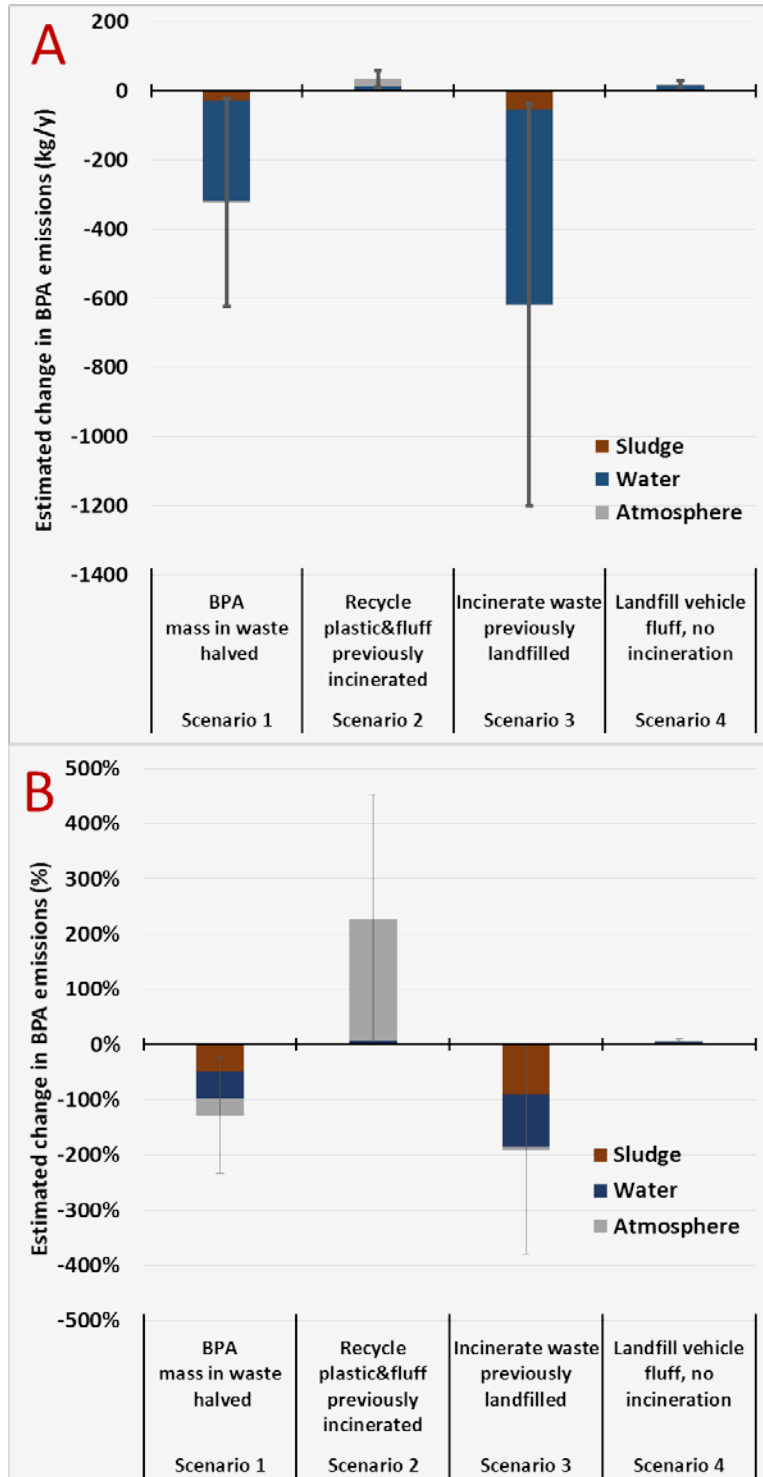

570
571
572
573
574
575

Figure 4. Comparison of BPA emissions resulting from different national waste management scenarios, showing changes in actual emissions (kg/y) in panel A or as percent difference (%) in panel B. Note that a positive change in the emissions would imply more BPA emitted to the environment than the current status quo model predicts, and vice versa.

576 The most substantial reduction in emissions of BPA presented in Figure 4 comes from
577 scenario 3, representing incineration of all waste that is currently landfilled. This scenario reduced
578 the total emissions of BPA by 618 kg/y (i.e. from 663 to just 45 kg/y). This is mainly due to
579 preventing release of BPA from landfilled plastic waste into leachate. The next most effective
580 scenario to reduce BPA emissions is Scenario 1, whereby reducing the concentrations in all
581 materials by half, or alternatively the produced amount of waste by half, leads to a direct reduction
582 in emissions by half, reducing the total amount of BPA emitted to 339 kg/y (and 321 kg/y just
583 from plastic). Scenarios 2 and Scenario 4 increased the BPA emitted, but only slightly, giving
584 totals of 678 and 695 kg/y compared to the current status quo of 663 kg/y. This is mainly because
585 these scenarios reduced the amount of BPA-containing waste being incinerated, and incineration
586 lowers BPA the most effectively. The emissions for initial recyclable processing, are mainly in the
587 air phase in the form of BPA-containing dust (from any shredding or crushing activities in poorly
588 ventilated areas).

589

590

591 **4. Conclusions and Outlook**

592 The results have importance from a regulatory perspective. Following Scenario 1, reducing
593 the amount of BPA entering the waste stream by reducing the amount of BPA in waste, is in theory
594 an efficient method to reduce emissions to air, water, and sludge. In practice, this does not seem
595 to be a realistic outcome in the near future, considering the increased worldwide production of
596 BPA, which is already estimated at over 4.6 million tons (Merchant, 2015), and the huge reservoir
597 of materials already containing BPA. An emerging issue in relation to BPA phase-out is the use of
598 potential BPA substitutes, which are most commonly other bisphenols such as bisphenol S and

599 bisphenol F. Many of these compounds are increasingly found in waste paper (Pivnenko et al.,
600 2015b), e-waste (Zhang et al., 2016) and WTP sludge (Lee et al., 2015; Yu et al., 2015); although
601 their risk to the environment is less well established.

602 The most immediate change in waste management that would result in lower BPA
603 emissions would be incinerating all BPA-containing waste that is currently sent directly to
604 landfills, following Scenario 3. This is further supported by Scenario 4, showing that landfilling
605 coarse car fluff in Norway would lead to higher emissions than the current practice of incineration.
606 Emissions could be further reduced by incinerating, rather, than recycling BPA-rich wastes
607 (Pivnenko et al., 2016a). However, this would go against current initiatives in Europe and Norway
608 to favor recycling over incineration (e.g. for vehicle fluff, Directive 2000/53/EC).

609 Management strategies at the facility level, or at the waste water infrastructure level, are
610 also important. For instance, the installation of air or water treatment systems at waste handling
611 facilities themselves, or ensuring that BPA emitting landfills are connected to a municipal WTPs
612 capable of removing BPA and its substitutes, would directly decrease environmental emissions,
613 particularly in regards to those stemming from landfill leachate.

614 As there is a drive to rapidly develop reuse and recycling schemes as part of the circular
615 economy, future research should focus on a better understanding of how contaminants like BPA
616 will be recycled into new products and emitted during recycling. Pivnenko et al. (Pivnenko et al.,
617 2016a) concluded that the most effective way to eliminate BPA from occurring in recycled paper
618 products is to eliminate BPA, but even if this is done it may take several decades before the
619 presence of BPA can be considered insignificant. Therefore, it may be needed to consider a
620 framework for the inclusion of compounds like BPA in recycled products, such as by specifying
621 acceptable levels of BPA in different types of recycled products, as part of the transition to the

622 circular economy. On the short-term, the best way to reduce environmental emissions based on the
623 results of this study are to preferably incinerate BPA-rich wastes, such as those containing
624 polycarbonate, epoxies and thermopaper, particularly if they are being landfilled, increase the
625 infrastructure of water treatment systems for landfill leachate, or to produce less BPA containing
626 waste.

627

628 **Acknowledgements**

629 Funding was provided by the Research Council of Norway (WASTEFFECT, 221440/E40). Frank
630 Wania (UTSC) helped design the CoZMoMAN modelling approach and gave critical feedback.
631 Geir Sørensen (Mepex), Rita Vigdis Hansen (Miljødirektoratet), Line Diana Blytt (Aquateam),
632 and Laila Borgen Skaiaa (RENAS) helped guide the direction of this research. The anonymous
633 reviewers are thanked for their constructive feedback.

634

635 **Supplementary Material**

636 Additional data, tables and figures are found in the Supplementary Material.

637

638 **References**

639
640 Norwegian Environment Agency, 2012a. Miljøgifter i produkter - data for 2009, Report TA-
641 2873; Miljødirektoratet: Oslo, 2012;
642 <<http://www.miljodirektoratet.no/old/klif/publikasjoner/2873/ta2873.pdf>>
643
644 Norwegian Environment Agency, 2012b. Økt utnyttelse av ressursene i plastavfall, Report TA-
645 2956; Miljødirektoratet: Oslo, 2012;
646 <<http://www.miljodirektoratet.no/old/klif/publikasjoner/2956/ta2956.pdf>>
647
648
649

650 Arp, H.P.H., 2013. Compilation of Norwegian Screening Data for Selected Contaminants (2002
651 – 2012). Miljødirektorat rapport TA 2982.

652 Breivik, K., Czub, G., McLachlan, M.S., Wania, F., 2010. Towards an understanding of the link
653 between environmental emissions and human body burdens of PCBs using CoZMoMAN.
654 Environment International 36, 85-91.

655 Cooper, J.E., Kendig, E.L., Belcher, S.M., 2011. Assessment of bisphenol A released from
656 reusable plastic, aluminium and stainless steel water bottles. Chemosphere 85, 943-947.

657 Cousins, I.T., Staples, C.A., Klecka, G.M., Mackay, D., 2002. A multimedia assessment of the
658 environmental fate of bisphenol A. Human and Ecological Risk Assessment 8, 1107-1135.

659 Czub, G., McLachlan, M.S., 2004. A food chain model to predict the levels of lipophilic organic
660 contaminants in humans. Environ. Toxicol. Chem. 23, 2356-2366.

661 EC, 2008. Updated European Risk Assessment Report, 4,4'-ISOPROPYLIDENEDIPHENOL
662 (BISPHENOL-A).

663 EC, 2015a. Additional analysis to complement the impact assessment SWD (2014) 208
664 supporting the review of EU waste management targets, SWD(2015) 259 final, Brussels, 2015;;
665 <http://eur-lex.europa.eu/legal-content/EN/TXT/?uri=CELEX:52015SC0259>.

666 EC, 2015b. Closing the loop - An EU action plan for the Circular Economy, COM(2015) 614
667 final, Brussels, 2015; [http://eur-lex.europa.eu/legal-](http://eur-lex.europa.eu/legal-content/EN/TXT/PDF/?uri=CELEX:52015DC0614&from=EN)
668 [content/EN/TXT/PDF/?uri=CELEX:52015DC0614&from=EN](http://eur-lex.europa.eu/legal-content/EN/TXT/PDF/?uri=CELEX:52015DC0614&from=EN).

669 EC, 2015c. Proposal for a DIRECTIVE OF THE EUROPEAN PARLIAMENT AND OF THE
670 COUNCIL amending Directive 2008/98/EC on waste, COM(2015) 595 final, Brussels, 2015;
671 <http://eur-lex.europa.eu/legal-content/EN/TXT/?uri=CELEX:52015PC0595>.

672 EE-registeret, 2012. EE-registeret Årsrapport 2011 (<http://www.eeregisteret.no/>, accessed
673 January 2015).

674 Fan, R., Zeng, B., Liu, X., Chen, C., Zhuang, Q., Wang, Y., Hu, M., Lv, Y., Li, J., Zhou, Y., Lin,
675 Z.Y.W., 2015. Levels of bisphenol-A in different paper products in Guangzhou, China, and
676 assessment of human exposure via dermal contact. Environmental Science: Processes & Impacts
677 17, 667-673.

678 Fuerhacker, M., 2003. Bisphenol A emission factors from industrial sources and elimination
679 rates in a sewage treatment plant. Water Science & Technology 47, 117-122.

680 Fürhacker, M., Scharf, S., Weber, H., 2000. Bisphenol A: emissions from point sources.
681 Chemosphere 41, 751-756.

682 Geens, T., Goeyens, L., Kannan, K., Neels, H., Covaci, A., 2012. Levels of bisphenol-A in
683 thermal paper receipts from Belgium and estimation of human exposure. Sci. Total Environ. 435,
684 30-33.

685 Gerrard, J., Kandlikar, M., 2007. Is European end-of-life vehicle legislation living up to
686 expectations? Assessing the impact of the ELV Directive on 'green' innovation and vehicle
687 recovery. Journal of Cleaner Production 15, 17-27.

688 Guerra, P., Kim, M., Teslic, S., Alae, M., Smyth, S.A., 2015. Bisphenol-A removal in various
689 wastewater treatment processes: Operational conditions, mass balance, and optimization. Journal
690 of Environmental Management 152, 192-200.

691 Klečka, G.M., Gonsior, S.J., West, R.J., Goodwin, P.A., Markham, D.A., 2001. Biodegradation
692 of bisphenol a in aquatic environments: River die-away. Environ. Toxicol. Chem. 20, 2725-2735.

693 Krogseth, I.S., Breivik, K., Arnot, J.A., Wania, F., Borgen, A.R., Schlabach, M., 2013.
694 Evaluating the environmental fate of short-chain chlorinated paraffins (SCCPs) in the Nordic

695 environment using a dynamic multimedia model. *Environmental Science-Processes & Impacts*
696 15, 2240-2251.

697 Laner, D., Feketitsch, J., Rechberger, H., Fellner, J., 2015. A Novel Approach to Characterize
698 Data Uncertainty in Material Flow Analysis and its Application to Plastics Flows in Austria.
699 *Journal of Industrial Ecology*, DOI: 10.1111/jiec.12326.

700 Lee, S., Liao, C., Song, G.-J., Ra, K., Kannan, K., Moon, H.-B., 2015. Emission of bisphenol
701 analogues including bisphenol A and bisphenol F from wastewater treatment plants in Korea.
702 *Chemosphere* 119, 1000-1006.

703 Liao, C., Kannan, K., 2011. Widespread Occurrence of Bisphenol A in Paper and Paper
704 Products: Implications for Human Exposure. *Environ. Sci. Technol.* 45, 9372-9379.

705 Limam, I., Mezni, M., Guenne, A., Madigou, C., Driss, M.R., Bouchez, T., Mazéas, L., 2013.
706 Evaluation of biodegradability of phenol and bisphenol A during mesophilic and thermophilic
707 municipal solid waste anaerobic digestion using ¹³C-labeled contaminants. *Chemosphere* 90,
708 512-520.

709 Lopez-Cervantes, J., Paseiro-Losada, P., 2003. Determination of bisphenol A in, and its
710 migration from, PVC stretch film used for food packaging. *Food Additives & Contaminants* 20,
711 596-606.

712 Merchant, 2015. Merchant Research & Consulting Ltd. Website:
713 <http://mcgroup.co.uk/news/20131108/bpa-production-grew-372000-tonnes.html> (Accessed Feb
714 9, 2015).

715 Mohapatra, D.P., Brar, S.K., Tyagi, R.D., Surampalli, R.Y., 2010. Physico-chemical pre-
716 treatment and biotransformation of wastewater and wastewater Sludge – Fate of bisphenol A.
717 *Chemosphere* 78, 923-941.

718 Morin, N., Arp, H.P.H., Hale, S.E., 2015. Bisphenol A in Solid Waste Materials, Leachate
719 Water, and Air Particles from Norwegian Waste-Handling Facilities: Presence and Partitioning
720 Behavior. *Environ. Sci. Technol.* 49, 7675-7683.

721 Naturvårdsverket, 2012. Report 6560: From waste management to resource efficiency.

722 Okkenhaug, G., Arp, H.P.H., 2012. Miljøgifter i sigevann fra avfallsdeponier i Norge. Data fra
723 perioden 2006–2010., Hovedrapport. TA-2978; Miljødirektoratet: Oslo, 2012.;

724 Pivnenko, K., Eriksson, E., Astrup, T.F., 2015a. Waste paper for recycling: Overview and
725 identification of potentially critical substances. *Waste Manage.* (Oxford),
726 dx.doi.org/10.1016/j.wasman.2015.1002.1028.

727 Pivnenko, K., Laner, D., Astrup, T.F., 2016a. Material Cycles and Chemicals: Dynamic Material
728 Flow Analysis of Contaminants in Paper Recycling. *Environ. Sci. Technol.* DOI:
729 10.1021/acs.est.6b01791.

730 Pivnenko, K., Olsson, M.E., Götze, R., Eriksson, E., Astrup, T.F., 2016b. Quantification of
731 chemical contaminants in the paper and board fractions of municipal solid waste. *Waste Manage.*
732 (Oxford) 51, 43-54.

733 Pivnenko, K., Pedersen, G.A., Eriksson, E., Astrup, T.F., 2015b. Bisphenol A and its structural
734 analogues in household waste paper. *Waste Manage.* (Oxford) 44, 39-47.

735 Sabbas, T., Poletini, A., Pomi, R., Astrup, T., Hjelmar, O., Mostbauer, P., Cappai, G., Magel,
736 G., Salhofer, S., Speiser, C., Heuss-Assbichler, S., Klein, R., Lechner, P., p, H.W.G.M.M.S.W.,
737 2003. Management of municipal solid waste incineration residues. *Waste Manage.* (Oxford) 23,
738 61-88.

739 Sadat-Shojai, M., Bakhshandeh, G.-R., 2011. Recycling of PVC wastes. *Polym. Degrad. Stab.*
740 96, 404-415.

741 Sajiki, J., Yonekubo, J., 2003. Leaching of bisphenol A (BPA) to seawater from polycarbonate
742 plastic and its degradation by reactive oxygen species. *Chemosphere* 51, 55-62.

743 Sajiki, J., Yonekubo, J., 2004. Leaching of bisphenol A (BPA) from polycarbonate plastic to
744 water containing amino acids and its degradation by radical oxygen species. *Chemosphere* 55,
745 861-867.

746 Sakhi, A.K., Lillegaard, I.T.L., Voorspoels, S., Carlsen, M.H., Loken, E.B., Brantsaeter, A.L.,
747 Haugen, M., Meltzer, H.M., Thomsen, C., 2014. Concentrations of phthalates and bisphenol A in
748 Norwegian foods and beverages and estimated dietary exposure in adults. *Environment*
749 *International* 73, 259-269.

750 Šala, M., Kitahara, Y., Takahashi, S., Fujii, T., 2010. Effect of atmosphere and catalyst on
751 reducing bisphenol A (BPA) emission during thermal degradation of polycarbonate.
752 *Chemosphere* 78, 42-45.

753 Santini, A., Passarini, F., Vassura, I., Serrano, D., Dufour, J., Morselli, L., 2012. Auto shredder
754 residue recycling: mechanical separation and pyrolysis. *Waste Manage. (Oxford)* 32, 852-858.

755 Staples, C.A., Dorn, P.B., Klecka, G.M., O'Block, S.T., Harris, L.R., 1998. A review of the
756 environmental fate, effects, and exposures of bisphenol A. *Chemosphere* 36, 2149-2173.

757 TechNavio, 2015. Global Bisphenol A Market 2015-2019, TechNavio, 2015;
758 <http://www.technavio.com/report/global-bisphenol-a-market-2015-2019>.

759 Thomas, K., Schlabach, M., Langford, K., Fjeld, E., Øknevad, S., Rundberget, T., Bæk, K.,
760 Rostkowski, P., Harju, M., 2014. Screening program 2013. New bisphenols, organic peroxides,
761 fluorinated siloxanes, organic UV filters and selected PBT substances. Miljødirektoratet Report
762 M-176/2014. ISBN 978-82-577-6431-9.

763 Vandenberg, L.N., Hauser, R., Marcus, M., Olea, N., Welshons, W.V., 2007. Human exposure to
764 bisphenol A (BPA). *Reproductive Toxicology* 24, 139-177.

765 Wania, F., Breivik, K., Persson, N.J., McLachlan, M.S., 2006. CoZMo-POP 2 - A fugacity-based
766 dynamic multi-compartmental mass balance model of the fate of persistent organic pollutants.
767 *Environmental Modelling & Software* 21, 868-884.

768 Ye, X.B., Pierik, F.H., Angerer, J., Meltzer, H.M., Jaddoe, V.W.V., Tiemeier, H., Hoppin, J.A.,
769 Longnecker, M.P., 2009. Levels of metabolites of organophosphate pesticides, phthalates, and
770 bisphenol A in pooled urine specimens from pregnant women participating in the Norwegian
771 Mother and Child Cohort Study (MoBa). *International Journal of Hygiene and Environmental*
772 *Health* 212, 481-491.

773 Yu, X., Xue, J., Yao, H., Wu, Q., Venkatesan, A.K., Halden, R.U., Kannan, K., 2015.
774 Occurrence and estrogenic potency of eight bisphenol analogs in sewage sludge from the US
775 EPA targeted national sewage sludge survey. *J. Hazard. Mater.* 299, 733-739.

776 Zhang, T., Xue, J., Gao, C.-z., Qiu, R.-l., Li, Y.-x., Li, X., Huang, M.-z., Kannan, K., 2016.
777 Urinary Concentrations of Bisphenols and Their Association with Biomarkers of Oxidative
778 Stress in People Living Near E-Waste Recycling Facilities in China. *Environ. Sci. Technol.* 50,
779 4045-4053.

780