

PAPER • OPEN ACCESS

## A review of the testing approaches in swelling rock conditions at three different institutions

To cite this article: L. Selen and K. K. Panthi 2021 *IOP Conf. Ser.: Earth Environ. Sci.* **833** 012034

View the [article online](#) for updates and enhancements.



**ECS** **240th ECS Meeting**  
Digital Meeting, Oct 10-14, 2021  
**We are going fully digital!**  
Attendees register for free!  
**REGISTER NOW**

# A review of the testing approaches in swelling rock conditions at three different institutions

L. Selen<sup>1</sup> and K. K. Panthi<sup>2</sup>

<sup>1</sup>Norwegian Geotechnical Institute (NGI), Oslo, Norway,

<sup>2</sup>Norwegian University of Science and Technology (NTNU), Trondheim, Norway

krishna.panthi@ntnu.no

**Abstract.** The swelling potential of weak rocks is crucial to assess in stability determinations of tunnels constructed for both infrastructure and hydropower. Among the institutions that are involved with extensive research on swelling rock material, the methodologies applied at three different European institutions are reviewed in this manuscript. XRD analysis and oedometer swelling tests are included as index tests at all three institutions whereby the adopted swelling test methodologies at all three institutions are grounded in the ISRM standards. Different mindsets in how to forecast the challenges related to swelling are, however, reflected in the boundary conditions of test procedures and the internal modifications on the test apparatus, the preparation procedure, and in the choice of specimen size/mass. This manuscript reviews the adopted methodologies and highlights the advantages and drawbacks on the testing approaches used. Two of the institutions rely on a general approach which is standardized, and the results are compared. It is highlighted that, both institutions have modified the ISRM standard and the methodologies represents two unique approaches. Institution 3 have a case-specific approach and no test data were available. However, the described methodology differs from the procedures at Institution 1 and 2. Important differences between the testing procedures are both discussed and exemplified by comparing the test results obtained from duplicate samples at two of the institutions.

## 1. Introduction

It is important to determine both rock properties and rock mass behaviour that are representative for the in-situ conditions. Rock samples are usually extracted from the project area and sent to the laboratories for testing so that it is possible to characterize the mechanical properties of rocks. Different procedures are available, but oedometer tests are most frequently used methods to evaluate the swelling potential of rocks and clay materials [1, 6]. Some researchers have introduced comprehensive test methodologies to reflect in-situ condition of the rock material at a specific location. Hence, the prevailing methodology in the investigation of swelling behavior of rocks for tunneling projects vary between institutions, both in identification and in the quantification of potential swelling.

The traditional approach in swelling rock assessment is to focus on the material properties and treat all rocks similar independent of case-specific in-situ conditions and characterize the results relative to each other. The produced database can be used to classify the tested rock material in different swelling class categories which then can be linked to the swelling behavior of rocks to case-specific projects [2]. Such a solution requires that the test procedure is strictly standardized in terms of preparation procedure, test methodology and equipment/apparatus used for the tests.

Another approach is to adopt the in-situ condition of the rock in the laboratory testing procedure. The moisture condition of the in-situ rock mass and the construction-specific exposure to moisture changes and unloading are, however, challenging tasks to simulate in the laboratory. The approach requires that the in-situ conditions are known, either by in-situ measurements or by qualified estimation based on empirical data. Moreover, the boundary conditions of the test are dependent on the unique situation of rock material tested and therefore may not produce comparable results. However, the output of the test may work as a case-specific simulation of in-situ behavior to be expected.



This manuscript presents an investigation on the prevailing swelling test approaches at three different European institutions where swelling behavior is assessed mainly based on the oedometer tests. Rock samples from two hydropower projects from Albania and from Philippines are tested at two of the reviewed institutions which are used for the comparison. However, the lack of test data from Institution 3 made it difficult to compare quantitatively. The main findings of the performed tests are used as basement for discussions on the different investigation approaches applied in swelling rock assessments. Finally, recommendations are made on the applicability of the test approaches in the assessment of swelling potential of rock material.

## 2. Overview of the assessed laboratory methods

Different laboratory testing methodologies have been developed aiming to characterize the swelling potential of rock materials and are illustrated in the recommendations by the ISRM Commission on Swelling Rocks [1, 3 & 4]). Depending on the test configuration, the tests measure maximum swelling deformation/strain, maximum swelling pressure when volumetric expansion is constrained, or a combination of both. Several variations of oedometer tests are being used around the world, whereas many of them are based on the work performed by Huder and Amberg [6] and by Grob [7]. In addition, different authors have been studying the swelling behaviour of rocks by triaxial testing [1] which involves comprehensive analyses on material properties, information on in-situ stresses and numerical modelling.

### 2.1. The maximum swelling pressure test

The most common procedure for swelling pressure test is the oedometer tests where a maximum swelling pressure is achieved with constrained radial and axial deformation restricting volume change in the specimen. During testing, the deformation produced by the swelling is compensated in the axial direction to keep the deformation constant. The applied load is measured, and the swelling pressure is calculated. The test is ideally performed on intact rock specimen, but when the rock material is too weak to withstand the preparation, powder samples are tested instead. Tests are performed in an acclimatized room with a constant temperature of about 20°C and relative humidity of about 40%. The test configuration suggested by ISRM [3 & 4] is widely used but with modifications at different institutions.

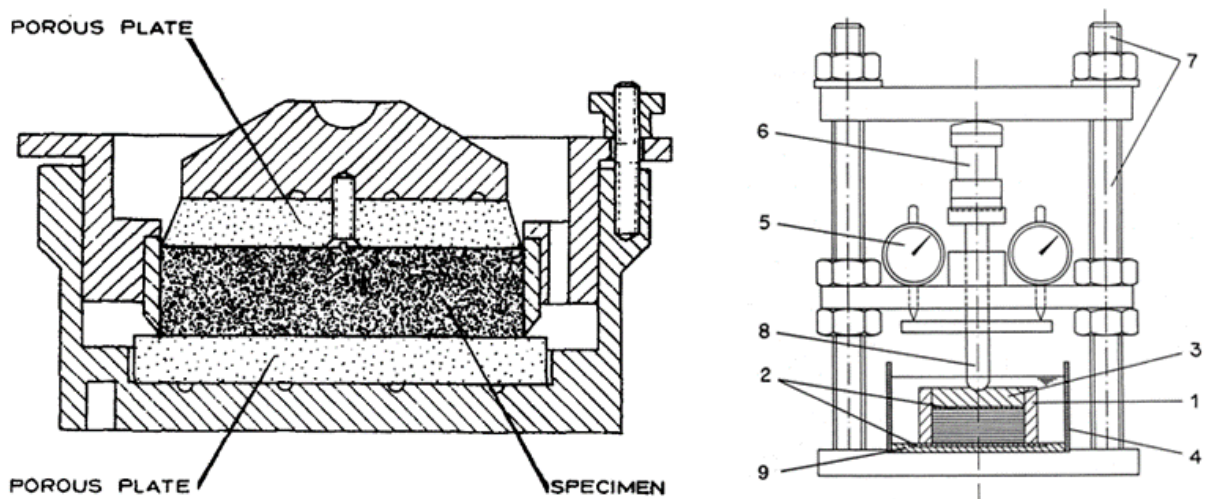

**Figure 1.** Maximum swelling pressure test configuration by ISRM [3 & 4] (left and right). In right figure: 1) stainless-steel ring, 2) porous metal plates, 3) stainless-steel loading plate, 4) container, 5) dial gages attached to the bottom of container, 6) load measuring device, 7) rigid frame, 8) loading piston and 9) stainless steel plate.

### 2.2. *The Huder-Amberg test*

The Huder-Amberg test is a combined swelling pressure and swelling strain oedometer test performed on intact rock samples initially consolidated in a non-dried state up to overburden stress regime. The test intends to measure axial swelling strain necessary to reduce the axial swelling stress of a radially constrained specimen immersed in water from its maximum value to a value which is within acceptable limit [1]. The test includes several initial loading and de-loading steps prior to the swelling phase of the test whereby in-situ moisture state of the rock is kept constant. Immediately after the in-situ overburden stress regime is reached, the sample is wetted and swelling allowed in axial direction i.e., under oedometric conditions. The applied load on the specimen is reduced in a stepwise manner until a new steady state is reached, up to a zero-strain situation. The relationship between swelling strain and swelling stress is plotted and a strain-stress curve (Grob's curve) is obtained, which is to be considered as the relationship between strain and stress for the tested rock material. The output of the test is dependent on the initial moisture state and stresses applied on the sample throughout the test procedure.

### 2.3. *Cyclic oedometer tests with controlled deformation*

The cyclic swelling test with controlled deformation is based on the work by Vergara and Triantafyllidis [8] and is a combination of the ISRM [4] swelling pressure test and the Huder-Amberg test. The first phase consists similar procedure as for the maximum swelling pressure test. After a maximum swelling pressure is reached, water is removed from the vessel and specimen is left to dry in laboratory climate until the pressure is stabilized. A second step is then initiated which either is a repeated maximum swelling pressure test or a swelling pressure test with controlled deformation. For the latter, a non-zero strain level is applied. This is realized by allowing some deformation while the sample swells during first watering cycle of the second step. The water used in the previous cycle is poured again into the vessel. Water loss by evaporation is refilled using demineralized water so that same water level is kept in the watering cell. This deformation level is again maintained constant during wetting-drying cycles. The allowed deformation usually results in a lower asymptotic peak swelling pressure compared to the first step. The number of cycles at each deformation level and number of deformation levels are decided based on the swelling behavior of specimen and the time available for the test.

## 3. The testing approach at three European institutions

The different institutions have different testing approaches in the assessment of swelling potential, where main deviating elements are boundary condition of the test procedures and state of the material tested. An overview of the principal elements of different approaches is summarized in table 1.

**Table 1.** Overview of principal elements in the different approaches in swelling tests

	Institution 1	Institution 2	Institution 3
Test category	Index	Index and behavioral	Behavioral
Boundary conditions	Standardized	Standardized	Case-specific
Sample state	Powder	Powder and intact	Intact

### 3.1. *Institution 1*

At Institution 1, the standard approach is to treat all rock material similarly to produce comparable results for quantification and characterization purpose. The in-situ condition of tested rock material in terms of initial moisture state and stress situation is ignored through the laboratory test procedure. Instead of using in-situ samples, remolded specimens consisting of sieved and dried clay powder are used for the tests. The reason for this is that in some occasion it is difficult to prepare samples representative of the in-situ rock material [9]. It is assumed that the use of remolded specimen represents a uniform and reproducible way for laboratory testing of the swelling materials. The procedure is based

on most of the swelling rock material tested at this institution, i.e. swelling gouge from weakness zones. When assessing the swelling potential of intact rocks, bulk powder is sometime used for the test.

The ISRM [3] method of oedometer maximum swelling pressure test (figure 1-left) is the prevailing method at this institution with some modifications on the procedure. The test can be performed on both sieved clay material from weakness zones and on pulverized bulk material of intact rocks. In the latter case, the rock material is crushed and milled to a size of less than 20  $\mu\text{m}$  and oven-dried at a temperature of 105°C. 20 grams of material is prepared into a 20  $\text{cm}^2$  test cell before the cell is placed in the oedometer apparatus, and the sample is compressed at 2 MPa for 24 hours before an unloading stage of 2 hours. The container surrounding the test cell is filled with distilled water and volume of the sample is remained constant by automated motor of the oedometer apparatus. The oedometer apparatus has no provision for axial deformation (strain) to be adjusted and hence the test procedure provides only maximum swelling pressure with constrained deformation (zero deformation). All tests are performed at the laboratory condition.

The swelling pressure is registered automatically for 24 hours by use of a software and the maximum swelling pressure is main output of the test. The results are characterized based on comparison to a large database of test results of the past. The characterization of swelling potential of pulverized intact rock material is based on the characterization system developed for the sieved clay powder tests (table 2). The results of the tests are used as index tests for tunnel rock support design decision.

**Table 2.** Swelling class classification based on swelling pressure values of

	Swelling pressure (MPa)
Inactive	<0.10
Medium active	0.10 – 0.30
Very active	0.30 – 0.75
Extremely active	>0.75

### 3.2. Institution 2

At Institution 2, a similar approach as in Institution 1 is operated. However, the methodology emphasizes intact rock testing and is customized to preserve the intact rock features during preparation and testing. Powder samples are mainly used when rock material is highly weathered, and an intact rock specimen is difficult to prepare. Modified versions of the ISRM [4 & 5] suggested method (figure 1-right) and the Huder-Amberg test are used for the laboratory set-up and oedometer apparatus configuration. The oedometer apparatus allows control on the deformation of and/or the load on the specimen to perform maximum swelling pressure test, axial deformation swelling test and combined swelling pressure/strain test. The oedometer configuration is assessed and modified in terms of decreased distance between the sample and the dial gauge(s) and the apparatus stiffness, in order to detect small increments in swelling pressure induced by intact rock specimen [8 & 10]. All tests are performed in an acclimatized room with a constant temperature of 20°C and relative humidity of 40%.

Institution 2 operates with two main test configurations, i.e., the maximum swelling pressure test and the cyclic swelling test with controlled deformation. For the maximum swelling pressure tests, for both powder and intact rock samples, the deformation produced by swelling is to be compensated manually during the test to keep the deformation constant. The intact rock specimens are prepared from core samples whereby a disk is cut from the drill core and trimmed using a lathe to achieve good fit into the oedometer ring. The prepared specimen typically has a diameter of 60 mm and height of 18–19 mm and is mounted in a watering vessel of the oedometer. A preload of 0,1 kN is applied to achieve a full contact between the filter slabs and the specimen. After a minimum time of 24 hours, demineralized water is filled into the watering vessel to activate swelling. Depending on the storage history of rock material prior to testing, no initial drying of the specimen is performed. The initial water content is measured and recorded. For the powder test, bulk rock material is milled and sieved to a maximum grain size of 250

$\mu\text{m}$ . The powder is air-dried and 100–120 g is compacted into a brass ring with a diameter of 60 mm by use of a hydraulic uniaxial testing machine. The load used to compact the powder is not specified, instead approximate density of intact rock is used as controlling parameter for the loading procedure.

### 3.3. Institution 3

At Institution 3, several swelling tests including different configurations of oedometer tests are operated depending on the aim of the investigation and the material to be tested. The two most frequently used swelling test methodologies for intact rock assessments are the Huder-Amberg oedometer test and the triaxial swelling test. The test principles of both test procedures, including extraction and preparation of test specimen, are based on the condition of the in-situ rock mass in terms of stresses and moisture content [11] and thereby differs from the methods at Institution 1 and Institution 2.

The identification of swelling potential is based on the mineralogical composition from XRD-analyses and the Huder-Amberg oedometer tests as modified by ISRM [4] & [1]. The results of the Huder-Amberg test are given in a plot of swelling strain (axial deformation) against axial stress (swelling pressure) where the resulting curves are considered as indicators on swelling characteristics of the rocks. Samples are then collected for triaxial swelling tests where the main objective is to simulate stress conditions experienced by rock support applied in the tunnel. The specimen preparation is carried out with great care to avoid any disturbance or free swelling prior to the test. The specimen size is around 70 mm in diameter and 140 mm in height. The triaxial swelling test in operation is based on the work of Barla [1] where a description of the full stress path of the rock is obtained by simulating three-dimensional conditions of a cylindrical specimen in a triaxial cell [11]. Due to practical reasons it was not possible to include experiments from this institution in the research period of this study.

## 4. Results and analyses from experiments at Institution 1 and Institution 2

Several flysch and volcanic rock samples were tested at Institution 1 and Institution 2 where a total of 14 duplicate rock samples of different quality underwent oedometer swelling pressure tests at both institutions. The samples were prepared and tested according to the prevailing methodology at each institution and the results were compared. At Institution 1, a characterization system is developed based on extensive datasets of results (table 2). A similar characterization system is lacking at Institution 2, as modifications on the methodology and apparatus are relatively recent.

### 4.1. Comparison of swelling pressure test results on powder samples

A comparison of the maximum swelling pressures obtained from powder sampled at Institution 1 and Institution 2 on duplicate samples are shown in figure 2.

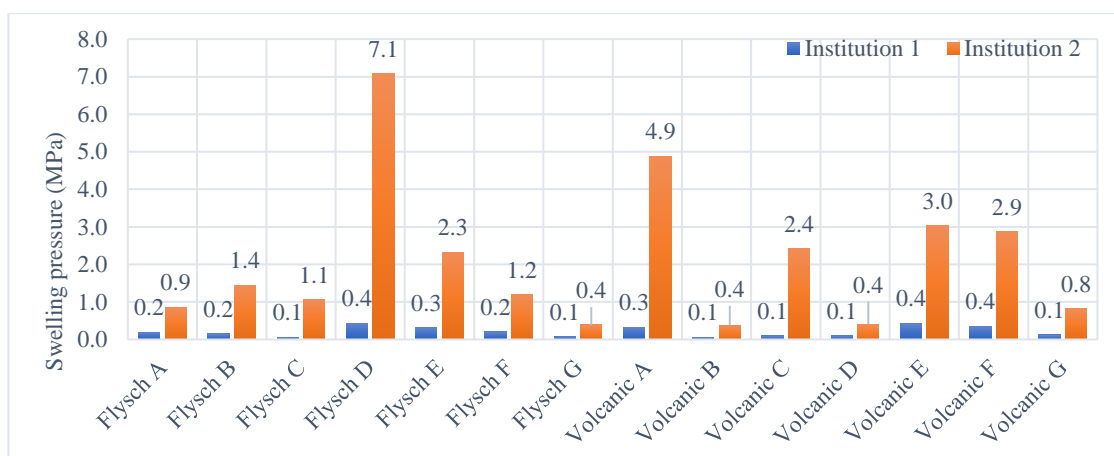

**Figure 2.** A comparison of the maximum swelling pressure (MPa) obtained from duplicate flysch and volcanic samples prepared and tested according to the prevailing methodology at Institution 1 and Institution 2



As seen in figure 2, the swelling pressure results obtained at Institution 2 are much higher compared to the results obtained at Institution 1. Since no characterization system is developed for the results at Institution 2, it is difficult to evaluate the indices from these tests. It should be noted here that some of the tested samples falling into class category of “inactive” according to the characterization system of Institution 1, a considerable swelling pressure is achieved during the test at Institution 2. Two examples of this phenomenon are the samples Flysch C and Volcanic C which fall into class category of “inactive” according to the categorization system of Institution 1. The obtained swelling pressure results for Flysch D and Volcanic A are found to be exceptionally high at the Institution 2 compared to Institution 1.

#### 4.2. Intact rock and powder swelling tests at Institution 2

A total of 3 flysch rock samples and 7 volcanic rock samples were tested to determine the maximum swelling pressure on both powder samples and intact rock disks. A comparison of the results of both tests on duplicate samples are shown in figure 3.

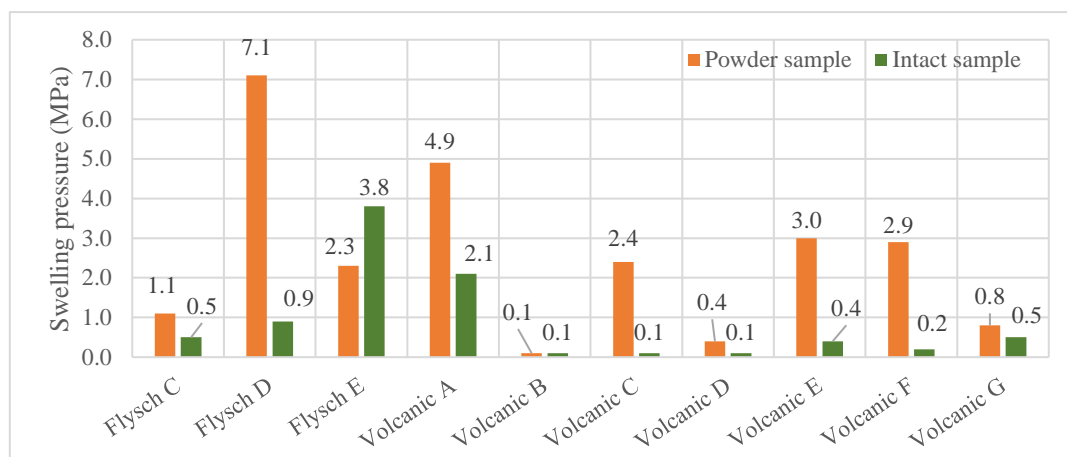

**Figure 3.** Comparison of swelling pressure results on powder samples and intact rock samples obtained at Institution 2.

As one can see in figure 3, the swelling pressure on powdered samples is much higher compared to the intact disk samples excluding Flysch E. This implies that structural features of the intact rock of Flysch E may interplay with an eventual swelling mineral, indicating that intact rock features should not be neglected in swelling investigations.

## 5. Discussions and conclusions

The prevailing methodology at Institution 1 and Institution 2 are closely related but internal modifications produce influences on the comparability [10]. In addition, a cyclic swelling test with controlled deformation is developed at Institution 2 which helps to simulate the in-situ condition of rocks in hydropower tunnels [8].

The advantage of the oedometer swelling pressure test procedure at Institution 1 is that it represents a quick, uniform, and reproducible way of laboratory testing of disturbed and disintegrated rock materials. The results indicate relative swelling potential of different materials which is valuable for the evaluation of potential stability problems of an underground opening. The main drawback of the procedure used is related to the extent of disturbance made on the rock material prior to swelling test. The in-situ structure, fabric, composition, and density of intact rock are damaged during preparation and milling process.

**Table 3.** Comparison of approach used in swelling tests at three institutions

	Institution 1	Institution 2	Institution 3
Preferred methods	Combination of free swelling test and oedometer swelling pressure test for milled rock powder	Combined oedometer swelling test for both intact rock and milled rock powder	Huder-Amberg oedometer test and triaxial swelling test
Standard	Modified version of ISRM [3]	Modified version of ISRM [4 & 5]	ISRM (1999) and Barla [1]
Preparation method	Pulverizing of rock material	Cut intact rock disks from borehole cores and/or pulverizing of rock material	Cut intact rock disks and/or cylindrical specimen from borehole cores
Initial moisture state	Oven-dried at 105 °C	Dried at <40 °C	In-situ state
Initial stress condition	Standardized	Standardized	In-situ state
Output	Maximum swelling pressure	Maximum swelling pressure and strain-stress relationship under cyclic deformation and moisture changes on intact rock sample	Swelling pressure/strain relationship (Grob's law) and/or triaxial swelling behavior

At Institution 2, the oedometer swelling pressure test on powder samples is mainly used in situations where the rock is too weak and disintegrated for intact specimen preparation techniques to be successful. The framework of the test is very similar to the test at Institution 1. However, the results obtained are considerably higher in magnitude. The explanation to higher swelling pressures may be related to a higher sensitivity of the oedometer apparatus, the compaction procedure, larger specimen size and manual operation [10]. However, the advantage of the oedometer configuration at Institution 2 is that it has a flexible and rational system of intact rock testing in addition to powder tests. The cyclic swelling test procedure is off course an added advantage. The test configuration is relatively new, resulting in a limited database of test results for swelling classification. Compared to the ISRM standard [5] test method, the procedure is time consuming as the test usually runs for months depending on the rock material and number of cycles to be used in cyclic tests.

Finally, the oedometer tests procedures used at Institution 3 have a potential to characterize in-situ swelling behavior. The Huder-Amberg test is used to generate input parameters for numerical modeling of swelling rock behavior. Provided that Grob's law prevails and that the rock mass is considered homogeneous, the stress-strain relationship of swelling can be applied for different states of in-situ stress at different locations along the tunnel. Among the drawbacks is time aspect. The test is cumbersome and may take months to years to finish it [12]. Further, the loads exerted to the samples are intended to simulate in-situ stresses, which is questionable due to uncertainties in estimating. In addition, the test assumes linearly elastic rock behavior which seldom is the case for weak and heterogeneous rock types. However, the triaxial swelling test coupled with numerical modeling has an advantage in determining the three-dimensional swelling properties of the rock mass around the tunnel periphery.

The oedometer testing approaches reviewed at these three institutions have their advantages and drawbacks. Swelling tests on pulverized bulk samples, as performed in Institution 1 and in Institution 2 are relatively quick, straight forward, and independent of rock mass quality. The extensive database of Institution 1 enables a classification of the results in different swelling classes which is being used by the tunneling industry for rock support design. On the other hand, the developed cyclic swelling pressure test methodology on intact rock samples under controlled deformation at Institution 2 provides an



opportunity to assesses swelling behavior of the intact rock when exposed to repeated moisture changes, which is an additional asset for tunnels built for hydropower projects.

The triaxial swelling test configuration developed at Institution 3 is an alternative that can be used if required time and resources are available. It is emphasized here that this method is developed to address in-situ rock condition at a laboratory scale causes certain level of uncertainty since a small cylindrical specimen cannot represent the whole rock mass that surrounds a tunnel.

## References

- [1] Barla M. 1999. Tunnels in Swelling Ground – Simulation of 3D stress paths by triaxial laboratory testing. *Ph.D. Thesis in Geotechnical Engineering. Politecnico di Torino*. 180 pp.
- [2] NFF. 2008. Håndbok no. 5. Tung bergsikring i undergrunnsanlegg. *Norsk Forening for Fjellsprengningsteknikk (NFF)*. ISBN 978-82-92641-09-5, 80p.
- [3] ISRM. 1979. Suggested methods for determining water content, porosity, density, absorption and related properties and swelling and slake-durability index properties: Part 1: Suggested methods for determining water content, porosity, density, absorption and related properties. *International Journal of Rock Mechanics and Mining Sciences and Geomechanics Abstracts* 16, 141–156.
- [4] ISRM. 1999. Suggested methods for laboratory testing of swelling rocks. *International Journal of Rock Mechanics and Mining Science* 36, 291-306.
- [5] ISRM. 1989. Suggested methods for laboratory testing of argillaceous swelling rocks. Commission on Swelling Rock. Coordinator: H. Einstein. *International Journal of Rock Mechanics and Mining Sciences and Geomechanics Abstracts* 26, 415–426.
- [6] Huder J and Amberg G. 1970. Quellung in Mergel. *Opalinuston und anydrit Schweizerische Bauzeitung* 88 (43), 975-980.
- [7] Grob H. 1972. Schwelldruck im Belchentunnel. *Proc. Int. Symposium on Underground Opening, Lucerne*, 99–119.
- [8] Vergara M and Triantafyllidis T. 2015. Swelling behavior of volcanic rocks under cyclic wetting and drying. *International Journal of Rock Mechanics and Mining Sciences* 80, 231-240.
- [9] Mao D. and Nilsen B. 2011. Laboratory Testing of Swelling Gouge From Weakness Zone - Principle And Recent Update. American Rock Mechanics Association: *Proc. of the 45th U.S. Rock Mechanics / Geomechanics Symposium*, 26-29 June, San Francisco, California.
- [10] Selen L, Panthi K K, Vergara M R. 2018. Swelling pressures of some rocks using different test procedures. *Proc. of the 2018 European Rock Mechanics Symposium (EUROCK 2018), Saint Peterburg, Russia, 22-26 May 2018* 1, 401-410.
- [11] Barla M. 2008. Numerical simulation of the swelling behaviour around tunnels based on special triaxial tests. *Tunnelling and Underground Space Technology* 23, 508–521.
- [12] Romana M and Serón J B. 2006. Characterization of swelling materials by Huder-Amberg oedometric test. *Proc. of the 16th International Conference on Soil Mechanics and Geotechnical Engineering*, 591–594.