

# COMPARING TOPOGRAPHICAL AND DYNAMICAL RUNOUT MODELS BY IDEAS OF „NEAREST NEIGHBOUR“ METHOD

Vergleich von topographischen und dynamischen Lawinenauslaufmodellen mit Hilfe der „Nearest Neighbour“ Methode

by

N66 S.BAKKEHØI, H.NOREM

## Abstract:

Different avalanche runout models are used to compare the calculated results against observations of 230 real avalanches in Norway. The parameters used in the models are investigated and optimized to get the best fit to the observed avalanches. A model has been developed that enables us to compare an avalanche path with the 230 others. The model finds the five best fitted paths compared with the path investigated. A method similar to what is used in avalanche hazard evaluation, the "Nearest Neighbour Method", where the Eulerian differences for a characteristic set of parameters are minimized.

## Zusammenfassung:

Zur vergleichenden Betrachtung von Felderhebungen an 230 Lawinen mit gerechneten Ergebnissen verwendet man in Norwegen verschiedene Modelle zur Bestimmung von Lawinenauslaufängen. Die für die Modellrechnung notwendigen Parameter werden untersucht und optimiert, um eine bestmögliche Übereinstimmung mit den beobachteten Lawinen zu erreichen. Daraus wurde ein Modell entwickelt womit man eine Lawinenbahn mit den anderen 230 vergleichen kann. Das Modell findet die fünf am besten übereinstimmenden Lawinenbahnen im Vergleich zur untersuchten Bahn. Eine Methode also ähnlich der, wie sie zur Beurteilung der Lawinengefahr angewandt wird, nämlich die „Nearst Neighbour Method“, wobei die mittleren Abstandsquadrate für eine bestimmte Anzahl von Parametern minimiert werden.

## 1. INTRODUCTION

Evaluation of the run-out distance and the speed profile for an avalanche is an important task in avalanche zoning and building of avalanche protections. The run-out distance is

dependent of the statistical probability of an avalanche of a certain size, and this is a function of the topography of the path, the climate at the site, the aspect, the height above sea level and the latitude.

A first attempt to solve the problem was the pioneering work of Voellmy (1955) who presented a flow model to calculate the velocity and the run-out distance. His model has been developed further and programs are made for calculation on computers.

In 1980 Lied and Bakkehoi presented a statistical model to calculate the maximum run-out distance based only on topographical parameters. The current topographical model is based on observations of 206 avalanches where there have been observations for more than 100 years.

In the last years, many different models, both dynamical and topographical, have been presented. In Norway, a model was developed by Norem, Irgens and Schieldrop (1989), the NIS-model. This is a two-dimensional continuum model treating the snow avalanche as a granular material having visco-plastic behaviour. The parameters in the model can be optimized by using the more than 200 different avalanche paths available, and an interesting matter is to compare the topographical model and the NIS model.

Throughout the years we have collected data from 230 interesting avalanches with known extreme runout distance. This avalanche library can be used as a reference avalanche library to compare unknown avalanches with paths equal to the path investigated. To find the best fit for a path, we use a similar method to that of avalanche hazard evaluation based on meteorological observations, called "nearest neighbour method". We are using some characteristic parameters describing the path like the total height difference, the curvature, the roughness etc. The difficulty with this model is to find the weighting coefficients for the parameters which are valid for all the avalanches.

## **2. BASIC IDEAS OF THE TOPOGRAPHIC MODEL**

The behaviour of snow avalanches differs substantially from one avalanche to the other next one, even in the same avalanche path. The variations cause that some avalanches obtain very low velocities and short run-outs compared to others. The difference is dependent on both the volume (or the flow height), the moisture of the snow and the size of the snow particles in motion.

Fitzharris and Schaerer (1980) showed that the maximum size of an avalanche in a certain path is a function of the return period. Norem (1991) has shown from full-scale experiments in Western Norway that the average velocity is directly related to the volume of the avalan-

che.

The basic idea of the topographical model is that for very long return periods the optimal snow conditions for an extreme avalanche will at least be obtained once. The climatic variations are thus assumed to have minor importance for return periods above approx. 100 years, and the effect of climatic variations may be excluded as a first approximation.

Consequently, the only remaining parameters are the topography of the avalanche path, which are objective parameters and not based on subjective judgement. The topographical model thus allows statistical analysis to be used to compare observed run-out distances to objective characteristics of the avalanche paths.

## RESULTS OF THE STATISTICAL ANALYSES

The study for the topographical model is based on observations of 206 avalanches. The avalanches have occurred in populated areas where the local population has had knowledge of the avalanche behaviour for more than 100 years. Each avalanche is plotted on maps, and the most probable starting point is defined.

The run-out distance of each avalanche is described with the angle  $\alpha$ , which is the angle from the starting point to the end of the observed debris, Fig. 1. This  $\alpha$ -angle is of common use in studying all kind of avalanches, e.g. rock avalanches and submarine slides, and represents an average, apparent friction angle along the avalanche path.

Several topographical parameters were tested statistically to find a relationship between the  $\alpha$ -angle and the characteristics of the avalanche path. The best agreement by using only one parameter was found with the  $\beta$ -angle. This angle represents the steepness of a line drawn from the starting point to the point in the path where the terrain gradient is  $10^\circ$ , Fig. 1. The  $\beta$ -point is a measure of the steepness of the avalanche track to the point where the run-out zone starts. The  $\beta$ -value has shown to be a very important parameter to characterize an avalanche path at least in the U-shaped valleys often found in Norway. In other types of avalanche terrain this parameter may have less importance.

The best fit between the  $\alpha$ - and  $\beta$ -values was found by the linear regression curve:

$$\alpha = 0.96 \beta - 1.4 \quad (1)$$

The standard deviation between the calculated and the observed  $\alpha$ -values was  $2.3^\circ$  and the correlation coefficient was 0.92. The plot of the observed and calculated values is shown in Fig. 2.

A deviation of  $2.3^\circ$  represents a deviation of 225 m if the vertical distance is 1000 m, the observed  $\alpha$ -angle is  $25^\circ$  and the run-out zone is horizontal.

A small improvement of the standard deviation was found by doing the regression analyses separately for three  $\beta$ -groups,  $\beta < 30^\circ$ ,  $30^\circ < \beta < 35^\circ$  and  $\beta > 35^\circ$ . The improvement is, however, not substantial.

Regression analyses were further carried out by studying the effect of the following parameters:

- Topography of starting zone
- Inclination of starting zone
- Supply of drifting snow to starting zone
- Width of starting zone
- Degree of confinement between starting zone and track
- Total vertical displacement
- Minimum curvature radius of path

All these parameters played a very minor role compared to the importance of the  $\beta$ -parameter. By including the gradient in the starting zone,  $\theta$ , the regression equation became:

$$\alpha = 0.94 \beta + 0.035 \theta - 2.6 \quad (2)$$

Equation 2 indicates that the  $\alpha$ -angle is increasing with increasing  $\theta$ -angles. In other words, a gentle slope in the starting zone favours a long run-out.

It is expected that the relationship between the  $\alpha$ - and the  $\theta$ -angle is an effect of the higher fracture heights and avalanche volumes often found in gentle starting zones. Low  $\theta$ -angles are also found mostly in gentle avalanche paths, and both the  $\beta$ - and the  $\theta$ -parameter are thus intercorrelated.

The next parameter having a distinct effect on the  $\alpha$ -value by the regression analyses was the vertical height difference,  $H$ , from the start to the stop. An increasing height resulted in a reduction in the run-out angle. This is obviously consequence of the increasing loss of heat energy in long avalanche paths. This type of energy is non-retrievable and will increase the apparent friction angle of the avalanche.

The other topographical parameters had a minor effect on the results of the regression analyses. Therefore it looks like they do not seem to have significant importance on the run-out distance of extreme avalanches.

Preliminary and recent studies indicate that there may be climatological dependencies on the run-out angle. Probably, the observed  $\alpha$ -angles are smaller when the run-out zone is in

mountain areas, where the average temperature is lower. There also seems to be a distinct difference from area to area even when the run-out zones are close to the sea level.

The topographical model has also been used outside Norway, e.g. McClung et al. (1989). This study found a statistical relationship between the  $\alpha$ - and the  $\beta$ -parameters. The constants in the regression equations had, however, a significant difference. The lowest  $\alpha/\beta$ -ratios were found in Sierra Nevada and the highest ratios in the Canadian parts of the Rocky Mountains.

The topographical model is assumed to represent a useful tool in estimating the run-out distance of extreme avalanches. The model must, however, be used with caution, and should not be extended to areas not covered by observations. The exclusion of climatic effects on the run-out angle can probably be justified for smaller areas, but not from one climatic area to another.

### 3. DYNAMICAL MODELS USED FOR STATISTICAL ANALYSES OF EXTREME AVALANCHE RUN-OUTS

The basic idea of the topographical model was to assume that the effects of climatic variations have only minor influence on the run-out distance of extreme snow avalanches. If this assumption is true, we should obtain a close relationship between the observed and calculated  $\alpha$ -angles based on dynamical models when keeping the properties of the snow constant, or only varying the topographical parameters.

The first attempt to analyse a dynamic model was made by Bakkehoi et al. (1983). The model developed by Perla, Cheng and McClung (1980), which is a revised Voellmy-model, was used for the analyses. The observed avalanches used for the comparisons were the same 206 avalanches used for the topographical model.

The input parameters in the PCM-model is the profile of the avalanche path, the dry friction coefficient,  $\mu$ , and a velocity dependent drag,  $D/M$ . The  $\mu$ -parameter was decided constant for all avalanches, and the  $D/M$ -parameter increased linearly with the height,  $H$ . The best fitted pairs for all paths were  $\mu = 0.25$  and  $D/M = 2Y$  with a standard deviation of  $3.5^\circ$  and  $R = 0.83$ . This is a higher deviation than observed by the topographical model.

The reason for the higher deviation may be explained by short-comings of the model or how to define the input parameters.

Preliminary analyses are recently made at NGI to exchange the PCM-model with the model developed by Norem, Irgens and Schieldrop (1989), the NIS-model. This model is a two-dimensional continuum model treating the snow avalanche as a granular material having visco-plastic behaviour. The main input parameters are the profile of the avalanche path, the

slab height in the starting zone, the length of the slab, the dry friction coefficient and the shear viscosity of the avalanching snow.

The input parameters used for the study are:

|  |                                |
|--|--------------------------------|
| Dry friction coefficient:  | 0.31                           |
| Shear viscosity:   | 0.0005 m'                      |
| Slab height (slope angle $\theta = 40^\circ$ ):  | 1.4 m                          |
| Slab length: The height differences of the slabs were selected to<br>1/20 times the height difference of the avalanche path: | $L = \frac{H}{20 \cos \theta}$ |

The slab height was selected to function as the slope angle in the starting zone, according to the ideas of Föhn (1981):

$$h\theta = 1.4 \frac{\sin 40 - 0.31 \cos 40}{\sin \theta - 0.31 \cos \theta} \quad (3)$$

Equation 3 has a slightly higher variation with  $\theta$  as proposed by Föhn (1981) and also used in the Swiss guidelines (Salm et al. 1990).

The results of the statistical analyses are shown in Fig. 3, and there is a distinct relationship between the calculated and the observed  $\alpha$ -angles. The standard deviation is found to be  $3.1^\circ$  and the correlation coefficient 0.87. These values are less satisfying than the topographical model, but are improved compared to the PCM-model.

Figure 3 shows that there are some avalanche paths that have a rather large deviation between the observed and calculated  $\alpha$ -values. Some of these deviations may probably be explained by uncertainties in the input data. Others have to be studied carefully in the field to understand why the avalanche behaves quite differently from one path to another. This study may show that other topographic parameters have to be defined and included, or that the differences from one area to another result in substantial differences for the run-out angles.

#### 4. THE „NEAREST NEIGHBOUR“ MODEL

When presenting an avalanche report to the public, we are often told that they do not believe that the avalanches will reach as far as we are concluding in the report. To convince our clients, we present avalanche profiles with known runout distance and equal to the path in question. This will often stop the discussion. These avalanches have up to now been picked

out by checking in older reports and looking at the profiles in our collection of 230 different avalanches.

For a long time there has been a desire to find similar avalanche paths by using the computer in the avalanche library. All the avalanche profiles we have been working with since 1980 have been stored on a digital form with the co-ordinates and the known longest runout distance. To automatize the finding of the most equal avalanches, we adopted a procedure used in avalanche hazard warning, called the "nearest neighbour" method (Buser, 1983).

The avalanche path is described with a set of parameters: total avalanche height difference  $H$ , the 10 degree point angle  $\beta$ , the angle in the starting Zone  $\theta$ ,  $y''$ ,  $H_{y''}$ , QDIF and SD2, where SD2 is the variance for the theoretical parabola fitted to the profile by the root square minimum method based on the co-ordinates for the profile. QDIF describes the differences between the real profile and the theoretical parabola. The parameters are then weighted with a coefficient  $k_i$ , and we calculate the n-dimensional distance,  $r$  :

$$r = \sqrt{\sum_{i=1}^n k_i \cdot \Delta x_i^2} \quad (4)$$

Finding the best coefficients is the most work-intensive job in this procedure. As the  $\beta$ -angle is a very important parameter in describing the profile, we decided to exclude avalanches differing more than two degrees from the investigated profile. We are now using a set of coefficients  $k_H = 0.01$ ,  $k_\beta = 1.0$ ,  $k_\theta = 0.3$ ,  $k_{y''} = 0$ ,  $k_{H_{y''}} = 0$ ,  $k_{QDIF} = 0.1$  and  $k_{SD2} = 0.1$ . An example of the result can be seen on figure 4.

When we have found the five most similar avalanches, we have the known runout distance for these avalanches. In addition, the runout distance is calculated using the topographical model and the NIS model as seen in the table on figure 4. This gives a comparison with more realistic avalanches, and it looks like the statistical deviations are less liable than when using one of the models alone, as seen on figure 5.

## 5. CONCLUSIONS

It is the authors point of view that statistical analyses of recorded extreme snow avalanches are a valuable tool in land-use planning. There is, however, no model that will give any exact answer to estimate the run-out distance and the avalanche speed. Any model has to be used with cautions and personal judgement and experience has to be considered for the final decision.

Experience has shown that using both a topographical, dynamical and a nearest neighbour model is more efficient than using only one.

## 6. REFERENCES

- Bakkehøi, S., Domaas, U. and Lied, K. (1983): Calculation of snow avalanche runout distance. *Annals of Glaciology*, Vol. 4.
- Buser, O. (1983): Avalanche Forecast with the Method of Nearest Neighbours: An Interactive Approach. *Cold Regions Science and Technology*, Vol. 8, No. 2, pp. 155-163.
- Fitzharris, B.B. and Schaerer, P. (1980): Frequency of major avalanche winters. *Journal of Glaciology* 26, (94), p. 43.
- Föhn, P. and Meister, R. (1982): Determination of avalanche magnitude and frequency by direct observations and/or with the aid of indirect snowcover data. *Mitteilungen der Forstlichen Bundesversuchsanstalt, Wien*, 144, pp. 207-228.
- Lied, K. and Bakkehøi, S. (1980): Empirical calculations of snow-avalanche run-out distance based on topographic parameters. *Journal of Glaciology* 26 (94), pp. 165-177.
- McClung, D., Mears, A.I. and Schaerer, P. (1989): Extreme avalanche run-out from four mountain ranges. *Annals of Glaciology*, Vol. 13.
- Norem, H., Irgens, F. and Schieldrop, B. (1989): Simulation of snow avalanche flow in run-out zones. *Annals of Glaciology*, Vol. 13.
- Norem, H. (1991): Discussion on the modelling of snow avalanche flow. *Mitteilungen EIFSL* No. 48, Davos.
- Perla, R., Cheng, T.T. and McClung, D.M. (1980): A two parameter model of snow avalanche motion. *Journal of Glaciology* 26 (94), pp. 197-207.
- Salm, B., Burkard, A. and Gubler, H. (1990): Berechnung von Fließlawinen. *Mitteilungen EIFSL* No. 47, Davos.
- Voellmy, A. (1955): Über die Zerstörungskraft von Lawinen. *Schweizerische Bauzeitung* 73 (12), pp. 159-162., (15), pp. 212-217, (17), pp. 246-249, (19), pp. 280-285.

### Authors' address/

### Adresse der Autoren:

S. BAKKEHØI

H. NOREM

Geotechnical Institute, P.O. Box 3930 Ullevaal Hageby  
N-0806 Oslo, Norway/Norwegen



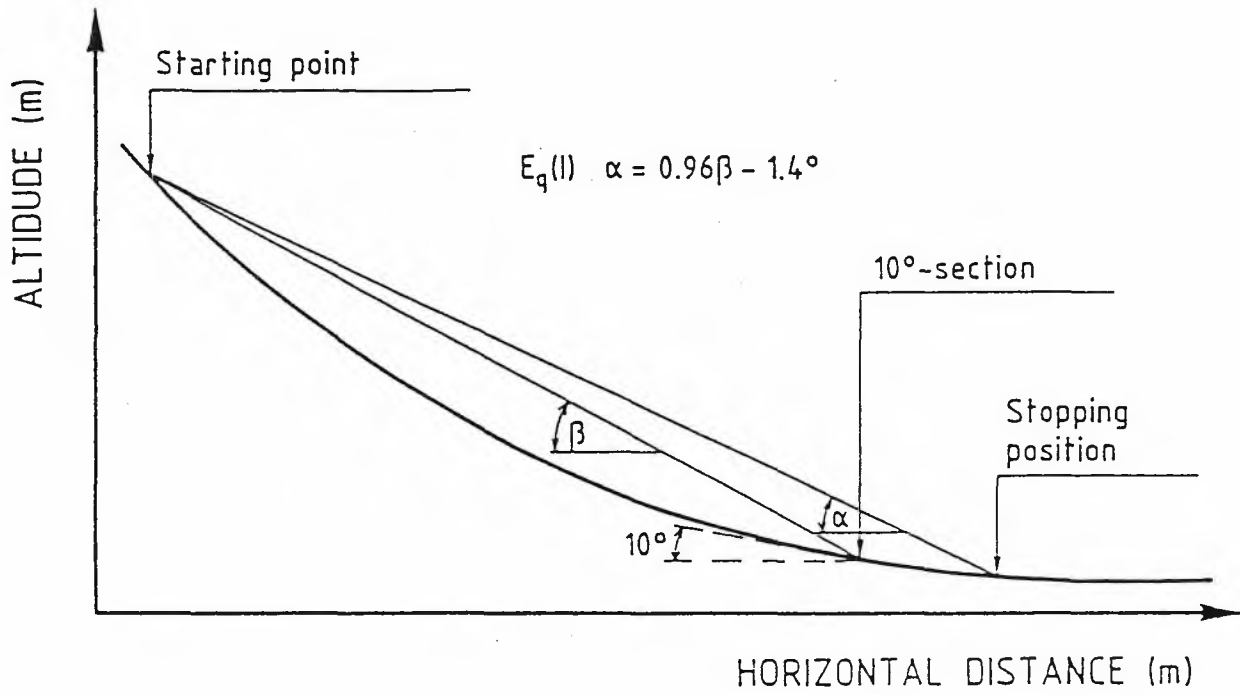

Fig 1 Topographical parameters for calculating maximum run-out distances

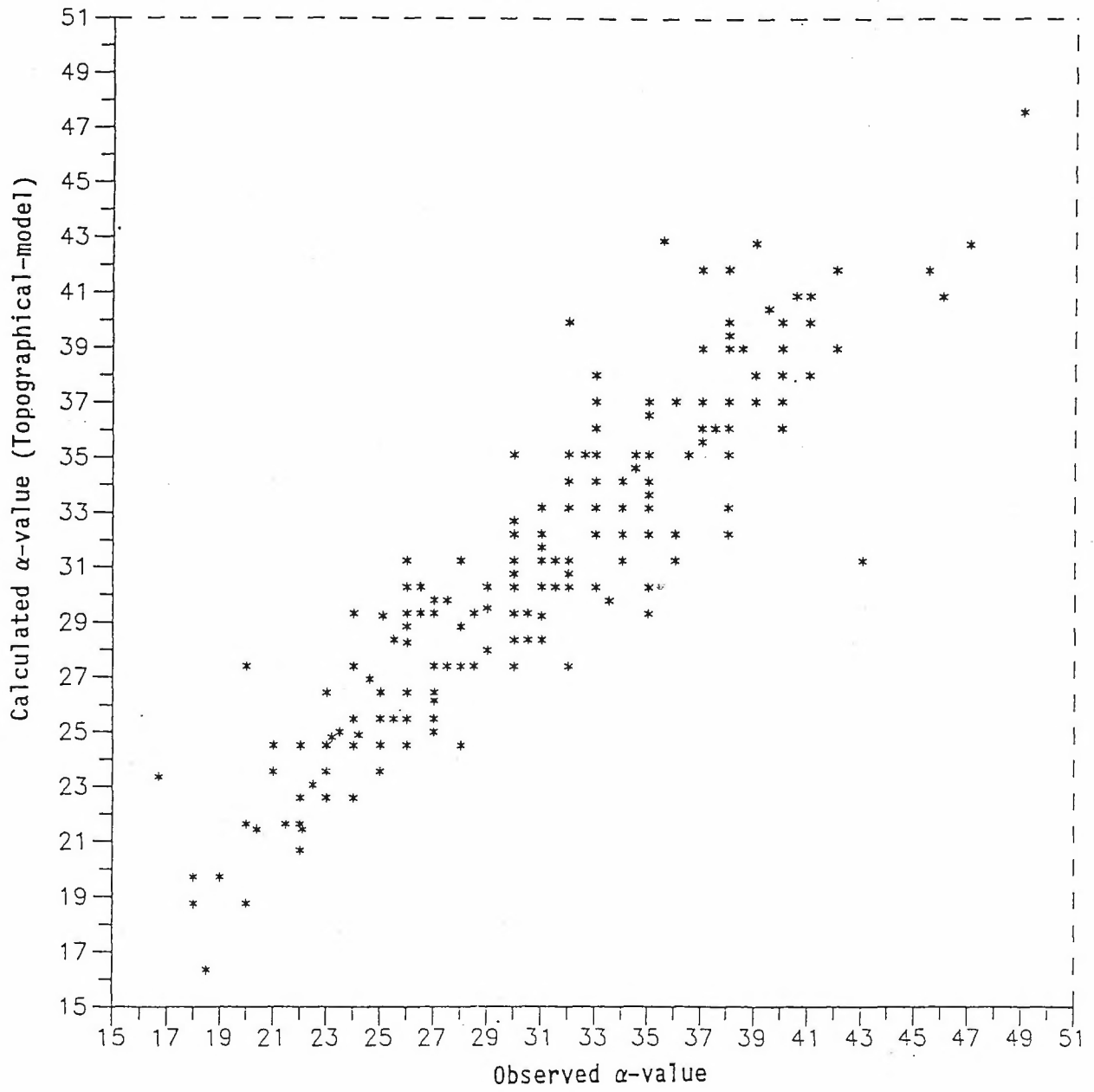

Fig 2 Observed and calculated  $\alpha$ -values by the topographical model

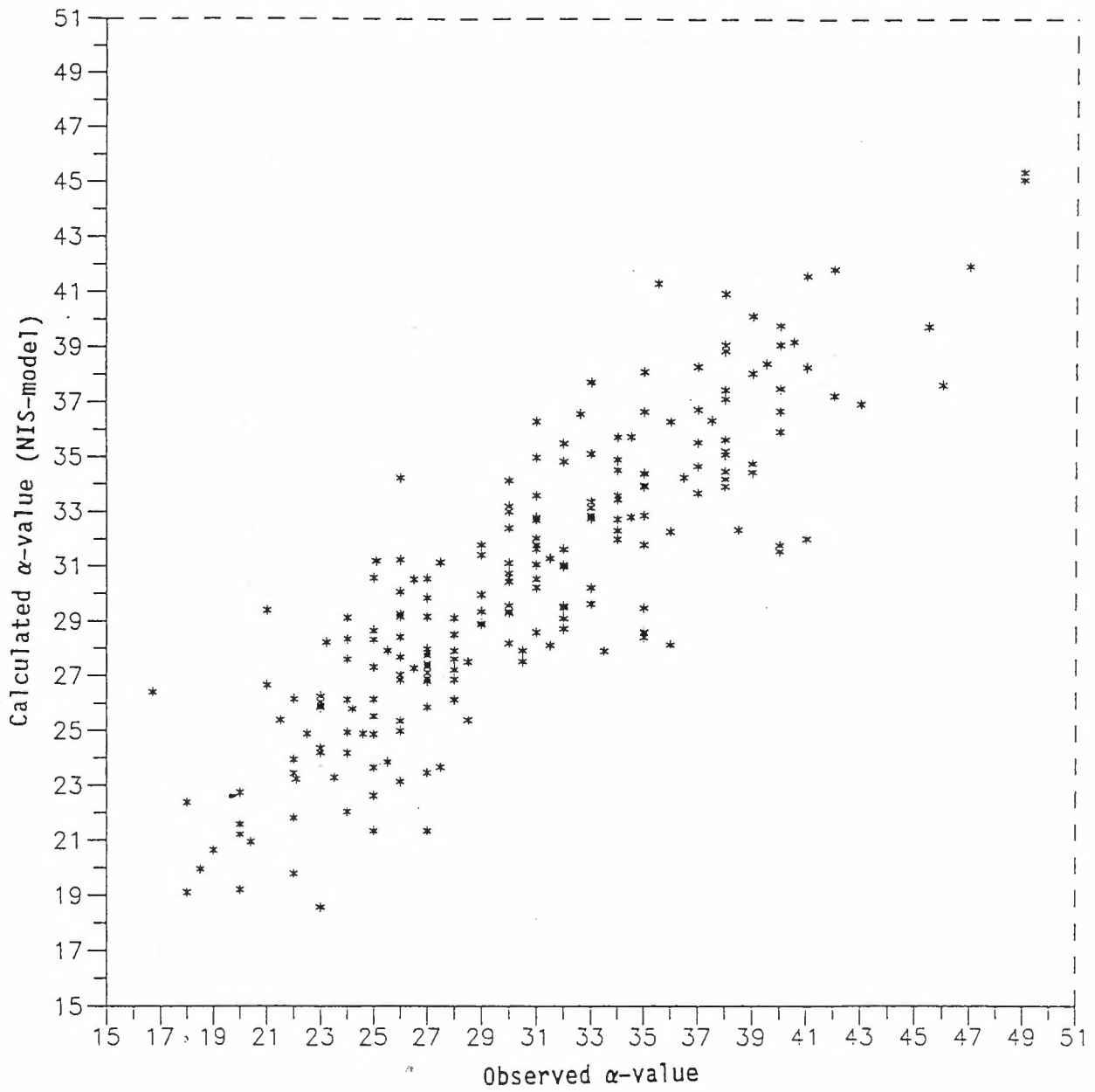

Fig 3 Observed and calculated  $\alpha$ -values by the dynamical model

## SAMMENLIKNING AV SKREDBANEPROFILER

Navn:

Kommune

Fylke

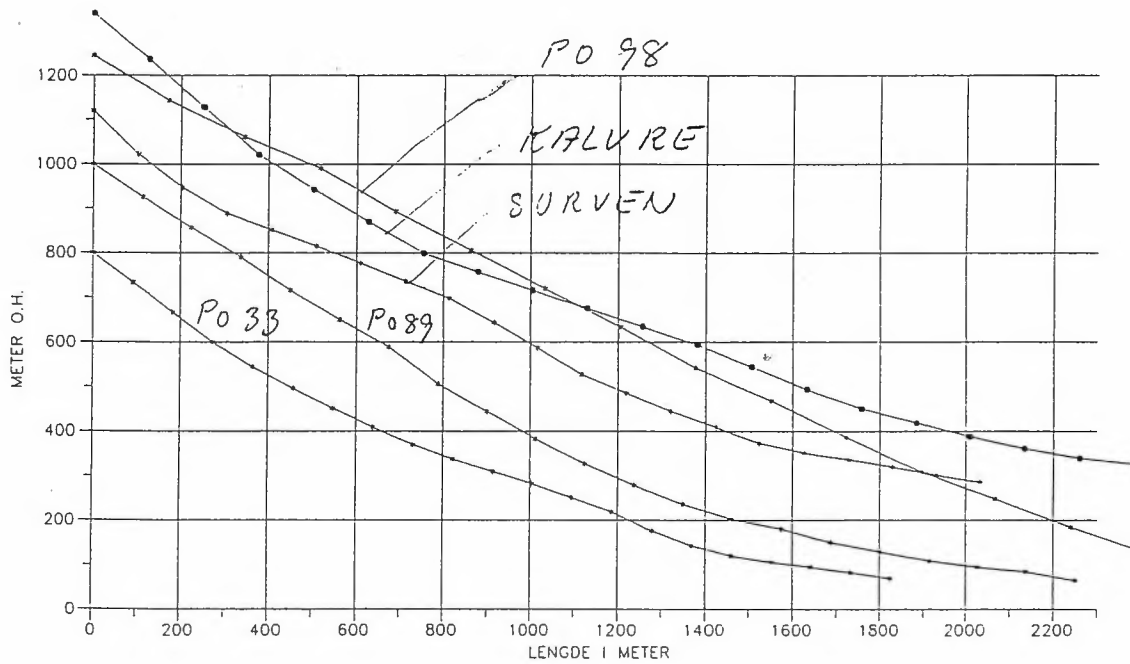

## BEREGNINGER CALCULATIONS

| Navn       | H  | Beta | Theta | Y-dob | H*Y-dob | Q-dif | SD-2 | Al-fa | Avvik | Al-fa STA | Al-fa NIS |
|------------|----|------|-------|-------|---------|-------|------|-------|-------|-----------|-----------|
| KATLURE 15 | 8  | 24   | 11.7  | 0     | 0       | 0.25  | 2.2  | 21.5  | 0     | 21.64     | 26.64     |
| SURVEN     | 8  | 25.5 | 12.9  | 0     | 0       | 0.28  | 1.9  | 22.5  | 2.421 | 23.08     | 24.75     |
| PO 33      | 8  | 25   | 11.4  | 0     | 0       | 0.116 | 1.1  | 22.0  | 2.556 | 22.6      | 24.0      |
| PO 98      | 12 | 24   | 12.0  | 0     | 0       | 0.21  | 2.7  | 20.0  | 2.664 | 21.64     | 22.06     |
| PO 89      | 10 | 26   | 13.2  | 0     | 0       | 0.08  | 1.2  | 23.0  | 2.669 | 23.56     | 25.12     |

ALFA-middel

21.8

22.5

24.4

Stand. avvik

1.15

0.85

1.5

Fig. 4